

LIMITED TENDER

No.PUR/HMBP/13/965427/MW-3605

Date: 21.01.2013



HEAVY MACHINE BUILDING PLANT HEAVY ENGINEERING CORPORATION LIMITED

(A Govt. of India Enterprises)

Ranchi - 834 004 (INDIA)

Phone : 0651-2400921 , 2401349

Fax : 0651-2401166, 2401571

E-mail : ukkrishna@hecltd.com

Web : hecltd.com

Materials Management Division

SCHEDULE OF ENQUIRY

Sl.No.	Drawing No	Description	Qty.reqd.
1	4301.69.890	Hydraulic Jack with hand pump consisting of the following main items :- (a)Hydraulic hand pump complete with tank, Release valve, Safety valve, Check valve, Pressure gauge, Tank capacity 10 Ltrs. Maximum Working pressure – 800 Kg per sq.cm. Discharge / Stroke – 20 CC (approx) Pressure gauge range – 0 to 1200 Kg. Per sq.cm. Outlet port 3/8” BSP Female. (b)High pressure hose NB10 complete with end fittings 3/8” BSP male, Maximum Working pressure – 800 Kg.per sq.cm., working medium – Hyd.Oil, Length = 3 Mtrs., Both end fittings 3/8”BSP Male with swivel femane nut and male adaptor. (c)Hydraulic Jack with handle, Load lifting capacity – 200T, Hydraulic lift (Stroke) 155mm, closed height 370mm, Ram dia – 180mm.	04No.
2	-	Hydraulic Jack 50T (Reversible) double acting with remote pump and hose, Lift – 450mm, Close Height – 600mm (maximum)	01 Nos.
3	1050.23.115	Hydraulic Jack Capacity 100T	08 Nos.

NOTE:For Item Sl.No.3 -

Please Furnish complete technical specification / Literature, Dimensioned Sketch / Drawing with BOM, make of seals, Quality Seals of reputed make only acceptable.

Note:

1. Please submit your quotation in two bid system i.e. (i) **Techno-commercial Bid.** & (II) **Price Bid**

2. Duly filled in terms & conditions to be submitted alongwith Technical (Techno-commercial) Bid.

Schedule of Tender receipt by **07.02.2013 upto 1.00 PM**. Opening of Tender on **07.02.2013, at 3.00PM** TENDERS must be submitted in sealed cover with Tender No. and the Due date superscribed on it failing which Tenders may be ignored.

In case of Two part bids (as mentioned above, the technical and commercial aspects to be sealed in a separate envelope superscribing Part-1 on it., The Price bid to be superscribed as Part - 2)

Special Instructions:

1. The rate quoted shall be inclusive of all packing & forwarding. Freight charges to be mentioned separately.
2. The Price quoted by the tenderer should be exclusive of sales tax. The rate and nature of sales tax applicable should be shown separately. Sales tax will be paid to the seller at the rate at which it is liable to be assessed or has actually been assessed on the date of supply provided the transaction of sale is legally liable to sales tax and within the delivery period. Any change on the taxes & duty structure beyond the delivery period will not be considered by HEC.
3. The rates quoted must be firm and the offers made must remain open for acceptance for three months from the date of opening of the tender.
4. Quotations erased or over written are likely to be rejected unless all corrections are authenticated with the tenderer's signature.
5. Delivery date offered must be specified and guaranteed.
6. Full payment will be made within 60 days of the receipt of supplies at destination duly inspected.
7. Full particulars i.e. specification, literature and / or drawing wherever applicable should be submitted alongwith the quotation. The brand and 'Make' name must be Indicated.
8. The Corporation does not pledge itself to accept the lowest or any tender and reserves to itself the right of accepting the whole or any part of tender or portion of the quantity offered and you shall supply the same at the rate quoted.
9. Supplies will be subject to Inspection by our Inspection wing / or inspection agencies prescribed by us.
10. Order placed as a result of this tender will be subject to the Corporation's General Terms and Conditions of contract which can be down loaded from our website (www.hecltd.com)
11. Corporation reserves the right to call for and examine at any time the books of accounts and other documents and papers of the firm for the purpose of ascertaining whether any excess payments has been made or the firm likely to be received / received undue benefit out of execution of the particular contract.
12. Delivery: The time for and the date of delivery of the Stores stipulated in the acceptance of tender shall be deemed to be the essence of the contract and delivery must be completed not later than the dates specified therein.
Otherwise:
 - a) The purchaser to recover from the contractor a sum of 0.5 % per week (completed week) of the price of the stores(upto maximum 10 %) as liquidated damages, which the contractor has failed to deliver as aforesaid or
 - b) The purchaser may procure the undelivered stores / similar items from elsewhere, without notice to the contractor at the risk of the contractor without canceling the contract in respect of the consignment not yet due for delivery or,
 - c) to cancel the contract or a portion thereof.

13. Income Tax Clearance Certificate - All tenderers shall submit along with their tender an Income Tax Clearance Certificate duly countersigned by the Income Tax Officer of the circle concerned under the seal of the office. Copy of Permanent Account No. (PAN) (of Income Tax) to be enclosed with the bid.
14. There is no obligation on our part to accept delayed / late tenders. Tenders received after the due date of opening are liable to be summarily rejected.
15. The rates quoted shall also be inclusive of embossing on the material. The Ownership namely HMBP / FFP / HMTP should be at a predominant place of the material to a size / thickness upon the volume of the material.

Special .Note:

While submitting tender pl. mentioned your Registration No. with HEC as a registered vendor with valid paper. If not pl. get registered your firm with HEC Limited immediately.

Signature of Purchase Executive

HEAVY ENGINEERING CORPORATION LIMITED

(A Government of India Enterprise)
HEAVY MACHINE BUILDING PLANT
MATERIALS MANAGEMENT DIVISION
P.O.DHURWA, RANCHI – 834004

Phone 0651-2400921/2401349,
Fax – 0651-2401166
E-mail : purhmbp@hecltd.com,

Date:

Terms & Conditions:

Sl. No.		HMBP/HEC Requirement	Bidders confirmation
1.	Price Terms (F.O.R. HMBP) Ex-Works /FOB	FOR HMBP Stores	
2.	Packing & Fwd.Charges	Free of Cost	
3a.	Central Excise Duty/Educ.CESS / S.Higher Educ.	To be quoted separately	
3b.	MODVAT Document to be provided	Document to be provided for availing MODVAT benefit	
4a.	Central Sales Tax	Separately	
4b.	Jharkhand VAT	Separately	
5.	Payment Terms	Within 60 days after receipt of material at HMBP Stores	
6.	Validity of offer	3 months.	
7.	Price variation clause	Not applicable	
8.	Delivery Schedule	Within 3 months from the GA Drawing approval	
9.	CENVAT document to be provided	a) Document to be provided. b) CENVAT included in quoted rate (in % of quoted rate)	
10.	Inspection	By QCA/HMBP at your works.	
11.	Insurance charges if any	To be quoted separately	
12.	Freight charges if Ex-works	To be quoted separately	
13.	Test Certificate and Guarantee Certificate	To be provided by manufacturer	
14.	PBG	10% of contract value to be provided before release of payment	
15.	G.A.Drawing	To be approved after receipt of order and before start of manufacturing.	
16.	Guarantee / Warranty	12 months from the date of commissioning or 18 months from the date of supply which ever is earlier.	

Note: Terms & conditions duly filled in to be submitted alongwith technical bid of offer otherwise your offer may not be evaluated.

4301.69.890

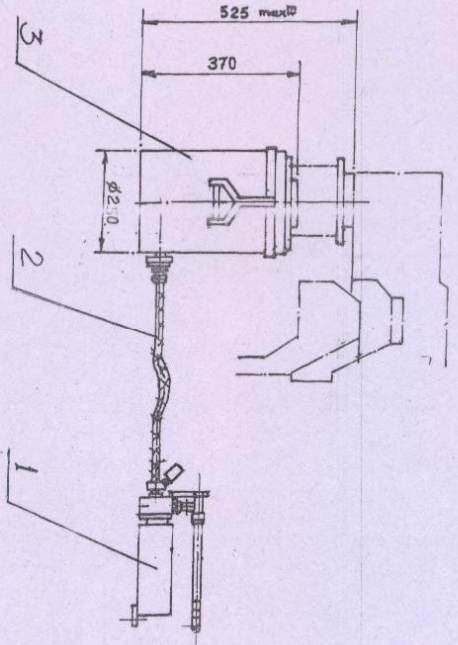

Technical Instructions

1. The complete system consisting of Item nos 1 to 3 are to be tested at a pressure of 1000 kg/cm² for proper functioning and leakproofness of the system
2. Make of items with complete BOM to be furnished alongwith offer.
3. The overall dimension of Jack is to be maintained as given in dty. This is to be indicated in offer.
4. End fitting of Hose item no-2 to be as per specification given in the dty. This is to be indicated in offer.

Index No.	Revision	Signature	Date

Co-ordinated with C.G. Bureau

Item No.	Dwg.No.	Description	Qty.	Remarks
3	-	Hydraulic Jack with handle. Load fitting Capacity:- 200T. Hydraulic Lift (stroke):- 155 mm. Closed Height :- Ram Dia.:- Base size (Dia):- Port size :- 3/8" Bsp. Female.	1	
2	-	High pressure Hose NB 10 Complete with end fittings. 3/8" Bsp male; working pressure - 1000kg/cm ² ; working medium - Hyd. oil; length - 3 M; both end fittings - 3/8" Bsp male with swivel female adaptor and male adaptor.	1	
1	-	Hydraulic hand pump complete with tank, Release valve, Safety valve, Check valve; Pressure gauge: Tank Capacity :- 10 ltrs. Working pressure:- 800kg/cm ² discharge/stroke:- 20 cc (approx) Pr. gauge range:- 0-1200 kg/cm ² Outlet Port size:- 3/8" Bsp. Female	1	



Hydraulic Jack with Hydraulic Hand pump.

4301.69.890

Ref. Dwg. No.	4301.69.890	SCALE:	200:00
GROUP LEADER	M. S. Muthu	DESIGNER	A. H. Ansari
DR. DING. NO.	NONA CH. D.	HE C LTD. RANCHI	Rev. 0

1050.23.115

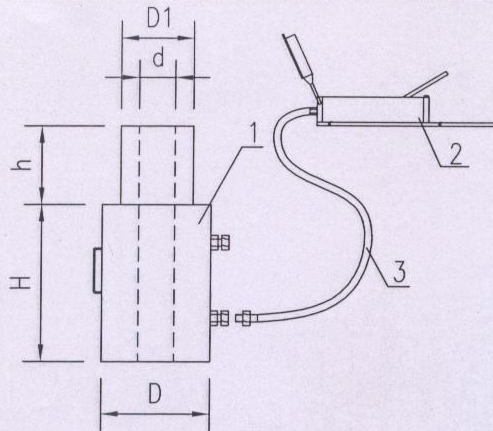

Technical Specification:

Heavy duty remote control Hydraulic jack Capacity - 100 T, consisting

1. Double Acting Hollow Plunger Hydraulic Cylinder , Lift (h) ~ 150 mm, .
Closed Height (H) ~ 280 mm (max.) Plunger Dia (D1) ~ 95 mm
Cylinder Body Dia. (D) ~ 165 mm
2. High Pressure Hydraulic Hand Pump, Working Pressure -700 bar
fitted with Pressure Gauge, Release Valve , Directional Control Valves
and other attachment / accessories.
3. High Pressure Flexible Hose fitted with End Fittings to suit the Jack.
4. Suitable lug to be provided at convenient position for handling / lifting
Cylinder / Pump

Bidder to furnish along with offer - complete technical specification / Literature,
Dimensioned Sketch / Drawing with BOM, make of seals. Quality Seals of
reputed make only acceptable.



Hydraulic Jack 100T

1050.23.115

MATERIAL-

BUREAU-CHIEF	R.Prasad	SCALE-	WEIGHT IN KG.- 55.00	
GROUP LEADER	P.R.K.Sinha	H.M.B. HEC LTD.,RANCHI		
DESIGNER	P.R.K.Sinha			Jan.-13
DRAWN BY				Rev.-0
REF.DRG.NO.				