



ISO 9001 Company

Heavy Engineering Corporation Limited
(A Govt. of India Enterprise)
Heavy Machine Building Plant
Ancillary & Contract Department

Open Tender Notice

Tender No. ACD/HMB/20/NFC/2128/OTE-6028 dtd 27.05.2020 is available on our website in e-procurement section i.e. <https://etenders.gov.in/eprocure/app>. Aspiring bidders may go through the tender document.

Interested bidders are requested to submit their most competitive offer through e-procurement mode only. Offer submitted through offline mode will not be considered. For more information please visit our website <https://etenders.gov.in/eprocure/app>.

Bid submission closing date	15.06.20	01:00 PM
Technical Bid opening date	16.06.20	03:00 PM

Prospective Tenderers are advised to get register themselves only on at NIC e-tender portal i.e. <https://etenders.gov.in/eprocure/app>, obtain 'User ID' & 'Password' and go through the 'Self Help files' available in the Home Page after log in to the portal <http://etenders.gov.in>. They should also obtain Class III Digital Signature Certificate (DSC) in parallel which is essentially required for submission of their application. Detailed instructions for online bid submission are attached in **annexure-5**. No registration fee would be charged from the bidders.

Bidders are required to upload the bid along with all supporting documents including priced part (BoQ) only on the e-tendering website (<https://etenders.gov.in/eprocure/app>), on or before the due date and time for submission of bid.

NOTE:

- 1. Any Future changes/notifications including extension of bid due date, pertaining to this tender will be published/hosted only on website & CPP Portal only.**



Submission of tender

The Following 2 covers shall be submitted through online CPP - portal by the bidders. Last date and time of submission of bids (cover 1, 2) is as per given dates.

Cover – I: - Containing techno-commercial bid

Cover – I containing

- i. Duly Filled Annexure-1
- ii. Ref. and PO as per Annexure 1, Sl. 2
- iii. Facilities available at your works for the same work/similar work as per Annexure 1, Sl. 3
- iv. All other documents as per Annexure 1 and Self Declaration as per Annexure 3

Cover - II: Price Bid (BoQ)

a) The tenderer shall upload the digitally signed Schedule of price bid in the form of BOQ.xls

Bidders may please note, the schedule of quantities is attached in the portal. The same (BOQ) shall be downloaded and be filled in the editable (un protected) cells only and they should necessarily submit their financial bids in the format provided after entering the financial quotes, name of the bidder etc.

Bid Opening Process is as below:-

Cover-I: Technical bid opening date will be as per given dates. If any clarification is needed from the bidder about the deficiency in his uploaded documents in Cover-I, he will be asked to provide it through Short fall documents folder in e-tendering portal one time only or through mail. The bidder shall upload the requisite clarification / documents within time specified by HEC, failing which tender will be liable for rejection.

Cover-II: The financial bids of the contractors / firms found to be meeting the qualifying requirements and technical criteria shall be intimated through portal. (Depending on Cover-I evaluation any changes in the date shall be intimated through e-tendering portal).



No.ACD/HMB/20/NFC/2128/OTE- 6028

Date: 27/05/2020

(A) **Scope of Supply**

HEC intends to procure the following Items. Interested firms are requested to submit their most competitive offer for supply of following item as per the technical Instructions and the terms & conditions given below.

Sl.No.	Dr.No.	Desc.	Qty	Wt/pc in Kg	Material Specification
1	1560.00.002	Bush	2	10	G1C BS:1400
2	1560.00.004	Bottom Bush	2	8	G1C BS:1400
3	1560.00.005	Top Bush	2	8	G1C BS:1400
4	1560.00.007	Barrel Bush	3	12	G1C BS:1400
5	1560.00.026	Bush	2	1.5	G1C BS:1400
6	1560.00.042	Bush (Split)	2	1	G1C BS:1400
7	1560.00.043	Bush (Split)	2	0.8	G1C BS:1400
8	1560.00.047	Pinion Bush	4	0.5	G1C BS:1400
9	1560.00.102	Bush	1	10	G1C BS:1400
10	1560.00.104	Bottom Bush	2	8	G1C BS:1400
11	1560.00.126	Brake Spindle	1	1.4	G1C BS:1400
12	1560.00.132	Bush (Split)	1	1	G1C BS:1400
13	1560.00.133	Bush (Split)	1	0.7	G1C BS:1400
14	1560.00.137	Pinion Bush	2	0.5	G1C BS:1400
15	1560.00.301	Barrel Bush	1	5	LG-4C BS:1400
16	1560.00.316	Top Bush	1	3.5	LG-4C BS:1400
17	1560.00.317	Lower Bush	1	3.5	LG-4C BS:1400
18	1560.00.318	Spacer	1	1.5	LG-4C BS:1400
19	1560.00.319	Ring	1	1.5	LG-4C BS:1400
20	1560.00.325	Bush	1	0.22	LG-4C BS:1400
21	1560.00.327	Bush	1	1.3	LG-4C BS:1400
22	1560.00.328	Trunion Nut	1	4.5	G1C BS:1400
23	1560.00.333	Bush	2	0.09	LG-4C BS:1400
24	1560.00.346	Bush	1	0.2	LG-4C BS:1400
25	1560.00.403	Bush	1	0.86	LG4C BS:1400
26	1560.00.404	Bush	1	0.7	LG4C BS:1400
27	1560.00.435	Bush	1	1.8	LG4C BS:1400
28	1560.00.458	Bush (Upper)	1	2.5	LG4C BS:1400
29	1560.00.497	Bush (Lower)	1	1.4	LG4C BS:1400
30	1560.00.507	Bush	1	0.056	LG4C BS:1400
31	1560.00.512	Bush	1	1.95	LG4C BS:1400
32	1560.00.529	Bush	1	0.09	LG4C BS:1400
33	1560.00.534	Bush	1	0.25	LG4C BS:1400
34	1560.00.554	Bush	1	0.05	LG4C BS:1400
35	1560.00.558	Bush	1	0.22	LG4C BS:1400
36	1560.00.564	Bush	1	0.056	LG4C BS:1400
37	1560.00.567	Bush	1	0.09	LG4C BS:1400
38	1560.00.569	Bush	1	0.054	LG4C BS:1400
39	1560.00.571	Bush	2	0.15	LG4C BS:1400
40	1560.00.576	Trunion Nut	1	0.5	G1C BS:1400
41	1560.00.578	Spacer	1	0.025	LG4 BS:1400
42	1560.00.601	Bush	1	14	G1C BS:1400
43	1560.00.602	Bush for Cable	2	10	G1C BS:1400
44	1560.00.606	Nut	1	15	G1C BS:1400
45	1560.00.429	Worm Gear Rim	1	9	PB 2C BS:1400



(B) Technical Instructions:

1. Items are to be supplied in rough machined condition (5 mm on tool point) and as per Drawing & its technical instructions/note.
2. Item Sl. No. 45 is to be casted with the Centrifugal Casting Process.
3. Casting to be witnessed by IRS (Indian Register of Shipping).
4. Chemical & Mechanical testing to be witnessed by IRS in IRS approved Lab.
5. Items will be procured on Package Basis and L1 firm will be decided based on the combined quoted value of Item Sl. No. 1 to 45. Quotation is to be submitted for all items otherwise your offer shall not be considered.

Note - The supplier has to give identification mark (to be indicated afterwards) on each item.

Terms & conditions

1. The rate quoted shall be Inclusive of all packing & forwarding, Freight charges & insurance on F.O.R HMBP Stores.
2. The Price quoted by the tenderer should be exclusive of GST. The rate and nature of GST applicable should be shown separately. GST will be paid to the seller at the rate at which it is liable to be assessed or has actually been assessed on the date of supply provided the transaction of sale is legally liable to GST and within the delivery period. Items will be procured on Package Basis and L-1 will be decided based on the combined quoted value of item Sl. No. 1 to 45.
3. **Validity of offer** - The rates quoted must be firm and the offer made must remain valid for acceptance up to **three months** from the date of opening of the tender. The rate quoted must be in word and figure as well. In case any discrepancy in rate given in figures and word, the rate given in words will prevail.
4. **Payment terms:** 90% payment along with 100% taxes and duties within two months of receipt of material in HMBP and 10% against C.R.V (to be issue by our Stores after receipt and acceptance of material at HMBP). In case of any deviation by the bidders necessary loading @ 1% Per Month (12% max Per Year) on quoted price shall be applicable and L-1 firm will be decided based on landed cost after loading on quoted price.
5. **Delivery Schedule –within 30 days from the date of issue of PO or 10 days from Inspection clearance by IRS/QCA HMBP.**
6. Full particular i.e. specification, literature and or drawing wherever applicable should be submitted along with the quotation.
7. The Corporation does not pledge itself to accept the lowest or any tender and reserve to itself the right of accepting the whole or any part of tender or portion of the quantity offered and you shall supply the same at the rate quoted.
8. **Inspection - Inspection will be done by IRS (Indian Register of Shipping) /QCA HMBP at supplier's works in stages, Necessary tools and measuring instruments to be provided by the supplier. Firm has to submit inspection call within delivery Schedule to Pur. (ACD) HMBP and based on that QCA HMBP/Marketing HEC will be raise the inspection call to IRS.**
 - a) **Firm has to submit Inspection Call min 3 days in advance for witness of Casting (Pouring).**
 - b) **Firm has to submit Inspection Call min 3 days in advance for witness of Chemical & Mechanical Testing in IRS approved Lab.**
9. Corporation reserves the right to call for and examine at any time the books of accounts and other document and papers of the firm for the purpose of ascertaining whether any excess payment has been made or the firm likely to be received / received undue benefit out of execution of the particular contract.
10. Earnest Money Deposit –Not Applicable



11. **Tender Fee –Rs 200/-** will have to be deposited by demand draft on any of the nationalized banks in favor of “Heavy Engineering Corporation Limited, payable at Ranchi. The copy of Tender Fee in form of DD will have to enclose in the Techno- Commercial bid (Part 1) and the original copy of the same has to reach before opening date of tender. Exemption of Tender Fee shall be applicable on submission of valid SSI/NSIC/MSME certificate and as per Govt rules. SSI/NSIC/MSME Certificate to be enclosed in Techno Commercial Bid Part 1.
12. **Security deposit (SD)** – Successful tenderers will have to deposit security equal to 5 % of the value of the contract within the desired period i.e. within 21 days of PO date. Failing this, the contract will be cancelled at the risk and expenses of the suppliers. SD will have to be deposited by demand draft on any of the nationalized banks in favor of “Heavy Engineering Corporation Limited, payable at Ranchi” or in the form of Bank Guarantee as per format at annexure-4.
13. **Delivery :** The time for and the date of delivery of the Stores stipulated in the acceptance of tender shall be deemed to be the essence of the Contract and delivery must be completed not later than the dates specified therein. Otherwise:
 - a. The purchaser to recover from the Contractor a sum of 0.5% per week (Completed week) of the price of the Stores (upto maximum 10%) as liquidated damages, which the contractor has failed to deliver as aforesaid or
 - b. The purchaser may procure the undelivered stores/ similar items from elsewhere, without notice to the contractor at the risk of the contractor without canceling the contract in respect of the consignment not yet due for delivery or
 - c. To cancel the contract or a portion thereof.
14. There is no obligation on our part to accept delayed / late tenders. Tenders received after the due date of opening are liable to be summarily rejected.
15. The rates quoted shall also be inclusive of embossing on the material. The ownership namely HMBP should be at a predominant place of the material to a size/ thickness upon the volume of the material.
16. The corporation reserves the right to reject any / all tender partly / fully and no tenderer can ask any explanation anywhere in this regard.
17. Successful Bidders have to sign the confidentially agreement in HEC’s format.
18. **Guarantee clause-** The items supplied shall be guaranteed for a period of 12 months from the date of commissioning or 18 months from the date of supply whichever is earlier against defective materials or bad workmanship
19. The repeat order for 100% quantity may be placed on successful bidder/bidders within one year from the date of delivery of the original Purchase Order on mutual agreement.
20. Order placed as a result of this tender will be governed by the Corporation’s General Terms and Conditions of Contract which can be referred in HEC’s website www.hecltd.com

Note:-

1. As per the govt. Guidelines it is to be specified clearly in your offer whether your firm is registered with SSI/NSIC/MSME and also confirm whether the firm is owned by SC/ST Entrepreneurs or not.
2. Pl. provide UAM no to avail Facilities of MSME.
3. Please get registered your firm with HEC Ltd.

(S.K.Singh)
DGM/ACD/HMBP
FOR AND ON BEHALF OF HEC Ltd.



ISO 9001 Company

**Heavy Engineering Corporation Limited
(A Govt. of India Enterprise)
Heavy Machine Building Plant
Ancillary & Contract Department**

Annexure – 1

PART – I (Techno - Commercial Bid)

No.ACD/HMB/20/NFC/2128/OTE-6028

Date: 27/05/2020

Sl.No.	Requisite		Remark
1	Whether the scope of Supply (A) & technical instruction (B) mentioned in the tender enquiry is acceptable.	Yes / No	
2	Reference & Photocopies of Major PO's placed on you by HEC /Other companies for same/similar items.	Yes / No	(Upload the relevant documents)
3	Duly notarized/Self Attested copies of Manufacturing Facilities (Casting, Machining, etc.) available at your works for the same work/similar work.	Yes / No	(Upload the relevant documents)
4	Whether SSI/NSIC/MSME (For exemption of Tender Fee only), Also mention UAN No.....	Yes / No	(Upload the relevant documents)
5	Whether Tender Fee deposited (As per clause 11 of Terms & conditions)	Yes / No	(Upload the copy of DD)
6	Items will be procured on Package Basis hence quotation is to be submitted for all items.PI confirm whether quoted for all items or not.	Yes / No	(In case your answer is No, then your offer shall not be considered)
7	F.O.R. HMBP (As per clause 1 of Terms & condition)	Yes / No	
8	Payment Term(As per clause 4 of Terms & condition)	Yes / No	(In case your answer is No, then please mention your term)
9	Delivery Term(As per clause 5 of Terms & condition)	Yes / No	(In case your answer is No, then please mention your term)
10	Validity (As per clause 3 of Terms & conditions)	Yes / No	
11	L.D. Clause(As per clause 13(a) of Terms & conditions)	Yes / No	
12	Risk Purchase Clause (As per clause 13(b) of Terms & conditions)	Yes / No	
13	Guarantee Clause (As per clause 18 of Terms & onditions)	Yes / No	
14	Security Deposit (As per clause 12 of Terms & conditions)	Yes / No	
15	GST	Yes / No	GST rate.....
16	Inspection (As per clause 8 of Terms & conditions)	Yes / No	
17	General Terms and Conditions of Contract (As per clause 20 of Terms & conditions)	Yes / No	
18	Firm is owned by SC/ST Entrepreneurs	Yes / No	
19	Whether Terms & Condition/Note etc. mentioned in the tender enquiry is acceptable to the tenderer	Yes / No	
20	Contact person Name: Email: Contact number:		

Note : In case of non-submission / submission of incomplete documents, your offer may not be considered for the said Enquiry.

(Signature of Tenderer)
With official Seal



ISO 9001 Company

Heavy Engineering Corporation Limited
(A Govt. of India Enterprise)
Heavy Machine Building Plant
Ancillary & Contract Department

Annexure – 2

PART-II (Price Bid)

The tenderer shall upload the digitally signed Schedule of price bid in the form of BOQ.xls

Bidders may please note, the schedule of quantities is attached in the portal. The same (BOQ) shall be downloaded and be filled in the editable (unprotected) cells only and they should necessarily submit their financial bids in the format provided after entering the financial quotes, name of the bidder etc.



ISO 9001 Company

Heavy Engineering Corporation Limited
(A Govt. of India Enterprise)
Heavy Machine Building Plant
Ancillary & Contract Department

Annexure – 3

No.ACD/HMB/20/NFC/2128/OTE-6028

Date: 27/05/2020

Self-Declaration

I _____, Son / Daughter of
Shri _____ age _____ years, resident of
_____ in the District of _____, do hereby
declare that all the information given in the offer and in the enclosed documents is true
to the best of my knowledge and belief and nothing has been concealed therein. I am
well aware of the fact that if the information given by me is proved false / not true at
any point of time, I will have to face punishment as per any provision of Law for the time
being in force as well as the benefit availed of by me or the benefit accrued to me shall
be summarily cancelled.

Date: -

(Signature of Tenderer)
With official Seal



Annexure 4

**Format for
BANK GUARANTEE FOR SECURITY DEPOSIT**

(to be issued by any Nationalized bank preferably State bank of India negotiable at their counters in Ranchi)

TO,

M/S HEAVY ENGINEERING CORPORATION LIMITED
PLANT PLAZA ROAD,
DHURWA,
RANCHI – 4

Dear sir,

In consideration of your agreeing to accept the security deposit of rs.'amount'..... furnishable to you by m/s 'firms name'..... (hereinafter referred to as contractor) in terms of the contract no.'hec's purchase order no'.....for supply of 'details of items'.....(hereinafter referred to as the 'contract') in the form of a bank guarantee in the manner hereinafter contained we.....'bank details'..... branch, having registered office at 'place'..... do hereby covenant and agree with you as follows:

1. We hereby undertake to indemnify you up to a sum of rs.'amount'.....(rupees 'amount in words'.....) against any loss or damage caused to or suffered by you or that may caused to or suffered by you by reason of any breach or breaches on the part of the contractor of any of the terms and conditions contained in the said contract and in the event the contractor shall make any default or defaults in carrying out any of the works under the said contract or otherwise in the observance and performance of any of the terms and conditions relating thereto in accordance with the true intent and meaning thereof, we shall forthwith on demand and without any protest or demur pay to you such sum or sums not exceeding in total the said sum of rs.'amount'.....(rupees 'amount in words'.....) as may be claimed by you as your losses and / or damages, costs, charges or



- expenses by reason of such default or defaults on the part of the contractor.
2. Notwithstanding anything to the contrary contained in this guarantee your decision as to whether the contractor has made any such default or defaults and the amount or amounts to which you are entitled by reasons thereof will be binding on us and we shall not be entitled to ask you to establish your claim or claims or damages or losses suffered by you but will pay the amount demanded by you under this guarantee forthwith on your demand without any protest or demur.
 3. This guarantee shall continue and hold good until it is released by you on the application by the contractor after expiry of the related warranty period of the said contract and after the contractor have discharged all their obligations under the said contract and produced a certificate of due completion of the work under the said contract and submitted a 'no demand certificate' provided always that this guarantee shall in no event remain in force after the date of ...'date'..... without prejudice to your claim or claims arisen and demanded from or otherwise notified to us in writing before the expiry of six months from the said date which will be enforceable against us notwithstanding that the same is or are enforced after the said date.
 4. We 'bank name'....., further undertake to extend the validity of this beyond the period prescribed in clause 3 or as extended from time to time, for such further period as may be required in writing before the expiry of this and upon such extension(s), all terms and conditions of this shall remain in full force till the expiry of this extended period(s).
 5. You will have the fullest liberty without affecting this guarantee from time to time to vary any of the terms and conditions of the said contract or extend the time of performance of the contractor or to postpone for any time or from time to time any of your rights or powers against the contractor and either to enforce or forebear to enforce any of the terms and conditions of the said contract and we shall not be released from our liability under this guarantee by the exercise of your liberty with reference to matters aforesaid or by reason of any time being given to the contractor or any other forbearance, act or omission on your part or any indulgence by you to the contractor or by any other variation or modification of the said contract or any other act, matter or things whatsoever, which, under the law relating to sureties, would but for the



provisions hereof, have the effect or so releasing us from our liability hereunder provided always that nothing herein contained will enlarge our liability hereunder beyond the limit of rs.'amount'.....(rupees 'amount in words'.....) as aforesaid or extend the period of the guarantee beyond the said date of ...'date'.... unless expressly agreed to by us in writing in terms of clause 4 hereof.

6. This guarantee shall not in any way be affected by your taking or varying or giving up any securities from the contractor or any other person, firm or company on its behalf or by the winding up, dissolution, insolvency or death as the case may be of the contractor.
7. In order to give full effect to the guarantee herein contained, you shall be entitled to act as if we are your principal debtors in respect of all your claims against the contractor hereby guaranteed by us as aforesaid and we hereby expressly waive all our rights of suretyship and other rights, if any, which are in any way inconsistent with any of the provisions of this guarantee.
8. Subject to the maximum limit of our liability as aforesaid this guarantee will cover all your claim or claims against the contractor from time to time arising out of or in relation to the said contract and in respect of which your claim in writing is lodged on us before expiry of six months from the date of expiry of this guarantee.
9. Any notice by way of demand or otherwise hereunder shall be in writing and may be sent by special courier, speed post or telefax to us at our local address as aforesaid.
10. This guarantee and the powers & provisions herein contained are in addition to and not by way of limitation of or substitution for any other guarantee or guarantees heretofore given to you by us whether jointly with others or alone and now existing uncancelled and that this guarantee is not intended to and shall not revoke or limit such guarantee or guarantees.
11. This guarantee shall not be affected by any change in the constitution of the contractor or us nor shall it be affected by any change in your constitution or by any amalgamation or absorption thereof or therewith but will ensure for the benefit of and be available to and enforceable by the absorbing or amalgamated company or concern.



12. This guarantee is irrevocable during the period of its currency and shall not be revoked without your previous consent in writing.
13. We further agree and undertake to pay you the amount demanded by you in writing irrespective of any dispute or controversy between you and the contractor or any reference to arbitration of the said dispute / controversy pending or a civil suit filed by the contractor in respect of the dispute or controversy.
14. Notwithstanding anything contained herein above our liability under this guarantee is restricted to rs.'amount'.....(rupees 'amount in words'.....) and this guarantee shall remain in force until 'date'.... unless a written claim is lodged on us for payment under this guarantee within six months from the date of expiry of this guarantee i.e. on or before ...'date' + '6 month'..... all your rights under this guarantee shall be forfeited and we shall be deemed to have released and discharged from all liabilities thereunder. irrespective of whether or not the original guarantee is returned to us.
15. We have power to issue this guarantee in your favour under the memorandum and articles of association of the bank and the undersigned has full power to execute this guarantee under the power of attorney granted to them by the bank.

FOR AND ON BEHALF OF
'name of bank'

'signature with seal'



Annexure-5
Instructions for Online Bid Submission

The bidders are required to submit soft copies of their bids electronically on the CPP Portal, using valid Digital Signature Certificates. The instructions given below are meant to assist the bidders in registering on the CPP Portal, prepare their bids in accordance with the requirements and submitting their bids online on the CPP Portal.

More information useful for submitting online bids on the CPP Portal may be obtained at: <https://eprocure.gov.in/eprocure/app>.

REGISTRATION

- (i) Bidders are required to enroll on the e-Procurement module of the Central Public Procurement Portal (URL: <https://etenders.gov.in/eprocure/app>) by clicking on the link "Online bidder Enrollment" on the CPP Portal which is free of charge.
- (ii) As part of the enrolment process, the bidders will be required to choose a unique username and assign a password for their accounts.
- (iii) Bidders are advised to register their valid email address and mobile numbers as part of the registration process. These would be used for any communication from the CPP Portal.
- (iv) Upon enrolment, the bidders will be required to register their valid Digital Signature Certificate (Class II or Class III Certificates with signing key usage) issued by any Certifying Authority recognized by CCA India (e.g. Sify / nCode / eMudhra etc.), with their profile.
- (v) Only one valid DSC should be registered by a bidder. Please note that the bidders are responsible to ensure that they do not lend their DSC's to others which may lead to misuse.
- (vi) Bidder then logs in to the site through the secured log-in by entering their user ID / password and the password of the DSC / e-Token.

SEARCHING FOR TENDER DOCUMENTS

- i) There are various search options built in the CPP Portal, to facilitate bidders to search active tenders by several parameters. These parameters could include Tender ID, Organization Name, Location, Date, Value, etc. There is also an option of advanced search for tenders, wherein the bidders may combine a number of search parameters such as Organization Name, Form of Contract, Location, Date, Other keywords etc. to search for a tender published on the CPP Portal.
- ii) Once the bidders have selected the tenders they are interested in, they may download the required documents / tender schedules. These tenders can be moved to the respective 'My Tenders' folder. This would enable the CPP Portal to



intimate the bidders through SMS / e-mail in case there is any corrigendum issued to the tender document.

- iii) The bidder should make a note of the unique Tender ID assigned to each tender, in case they want to obtain any clarification / help from the Helpdesk.

PREPARATION OF BIDS

- i) Bidder should take into account any corrigendum published on the tender document before submitting their bids.
- ii) Please go through the tender advertisement and the tender document carefully to understand the documents required to be submitted as part of the bid. Please note the number of covers in which the bid documents have to be submitted, the number of documents - including the names and content of each of the document that need to be submitted. Any deviations from these may lead to rejection of the bid.
- iii) Bidder, in advance, should get ready the bid documents to be submitted as indicated in the tender document / schedule and generally, they can be in PDF / XLS / RAR formats. Bid documents may be scanned with 100 dpi with black and white option which helps in reducing size of the scanned document.
- iv) To avoid the time and effort required in uploading the same set of standard documents which are required to be submitted as a part of every bid, a provision of uploading such standard documents (e.g. PAN card copy, annual reports, auditor certificates etc.) has been provided to the bidders. Bidders can use "My Space" or "Other Important Documents" area available to them to upload such documents. These documents may be directly submitted from the "My Space" area while submitting a bid, and need not be uploaded again and again. This will lead to a reduction in the time required for bid submission process.

Note: My Documents space is only a repository given to the Bidders to ease the uploading process. If Bidder has uploaded his Documents in My Documents space, this does not automatically ensure these Documents being part of Technical Bid.

SUBMISSION OF BIDS

- i) Bidder should log into the site well in advance for bid submission so that they can upload the bid in time i.e. on or before the bid submission time. Bidder will be responsible for any delay due to other issues.
- ii) The bidder has to digitally sign and upload the required bid documents one by one as indicated in the tender document.
- iii) Bidder has to select the payment option as "offline" to pay the tender fee / EMD as applicable and enter details of the instrument.



- iv) Bidder should prepare the EMD as per the instructions specified in the tender document. The original should be posted/couriered/given in person to the concerned official, latest by as specified in the tender documents. The details of the DD / any other accepted instrument, physically sent, should tally with the details available in the scanned copy and the data entered during bid submission time. Otherwise the uploaded bid will be rejected.
- v) Bidders are requested to note that they should necessarily submit their financial bids in the format provided and no other format is acceptable. If the price bid has been given as a standard BOQ format with the tender document, then the same is to be downloaded and to be filled by all the bidders. Bidders are required to download the BOQ file, open it and complete the white coloured (unprotected) cells with their respective financial quotes and other details (such as name of the bidder). No other cells should be changed. Once the details have been completed, the bidder should save it and submit it online, without changing the filename. If the BOQ file is found to be modified by the bidder, the bid will be rejected.
- vi) The server time (which is displayed on the bidders' dashboard) will be considered as the standard time for referencing the deadlines for submission of the bids by the bidders, opening of bids etc. The bidders should follow this time during bid submission.
- vii) All the documents being submitted by the bidders would be encrypted using PKI encryption techniques to ensure the secrecy of the data. The data entered cannot be viewed by unauthorized persons until the time of bid opening. The confidentiality of the bids is maintained using the secured Socket Layer 128 bit encryption technology. Data storage encryption of sensitive fields is done. Any bid document that is uploaded to the server is subjected to symmetric encryption using a system generated symmetric key. Further this key is subjected to asymmetric encryption using buyers/bid openers public keys. Overall, the uploaded tender documents become readable only after the tender opening by the authorized bid openers.
- viii) The uploaded tender documents become readable only after the tender opening by the authorized bid openers.
- ix) Upon the successful and timely submission of bids (i.e. after Clicking "Freeze Bid Submission" in the portal), the portal will give a successful bid submission message & a bid summary will be displayed with the bid no. and the date & time of submission of the bid with all other relevant details.
- x) The bid summary has to be printed and kept as an acknowledgement of the submission of the bid. This acknowledgement may be used as an entry pass for any bid opening meetings.



ISO 9001 Company

Heavy Engineering Corporation Limited
(A Govt. of India Enterprise)
Heavy Machine Building Plant
Ancillary & Contract Department

ASSISTANCE TO BIDDERS

- i) Any queries relating to the tender document and the terms and conditions contained therein should be addressed to the Tender Inviting Authority for a tender or the relevant contact person indicated in the tender.
- ii) Any queries relating to the process of online bid submission or queries relating to CPP Portal in general may be directed to the 24x7 **CPP Portal** Helpdesk.

Note: For any query related to registration and processing on the Portal please visit

FAQ available at

<https://etenders.gov.in/e procure/app?page=FAQFrontEnd&service=page>

You may call the Helpdesk. The 24 x 7 Help Desk Numbers are
0120-4200462, 0120-4001002, 0120-4001005, 0120-6277787
E-Mail: support-eproc@nic.in

Or

You may call to our service provider, Mr.Kushal (7903884318)
E-Mail: kushalniccl@gmail.com

1560.00.002

GARDEN REACH SHIPBUILDERS & ENGINEERS LTD. CALCUTTA.

DECK MACHINERY DIVISION

DRAWN *for sign* DATE: 17.5.89

DESCRIPTION

SK No. 4,07026

TRACED DATE:

BUSH

REV.

CHECKED *(Signature)* DATE: 17.9.88

MATERIAL - G1C, B.S. 1400

SCALE - 1:2

EST. WT - 10 KGS.

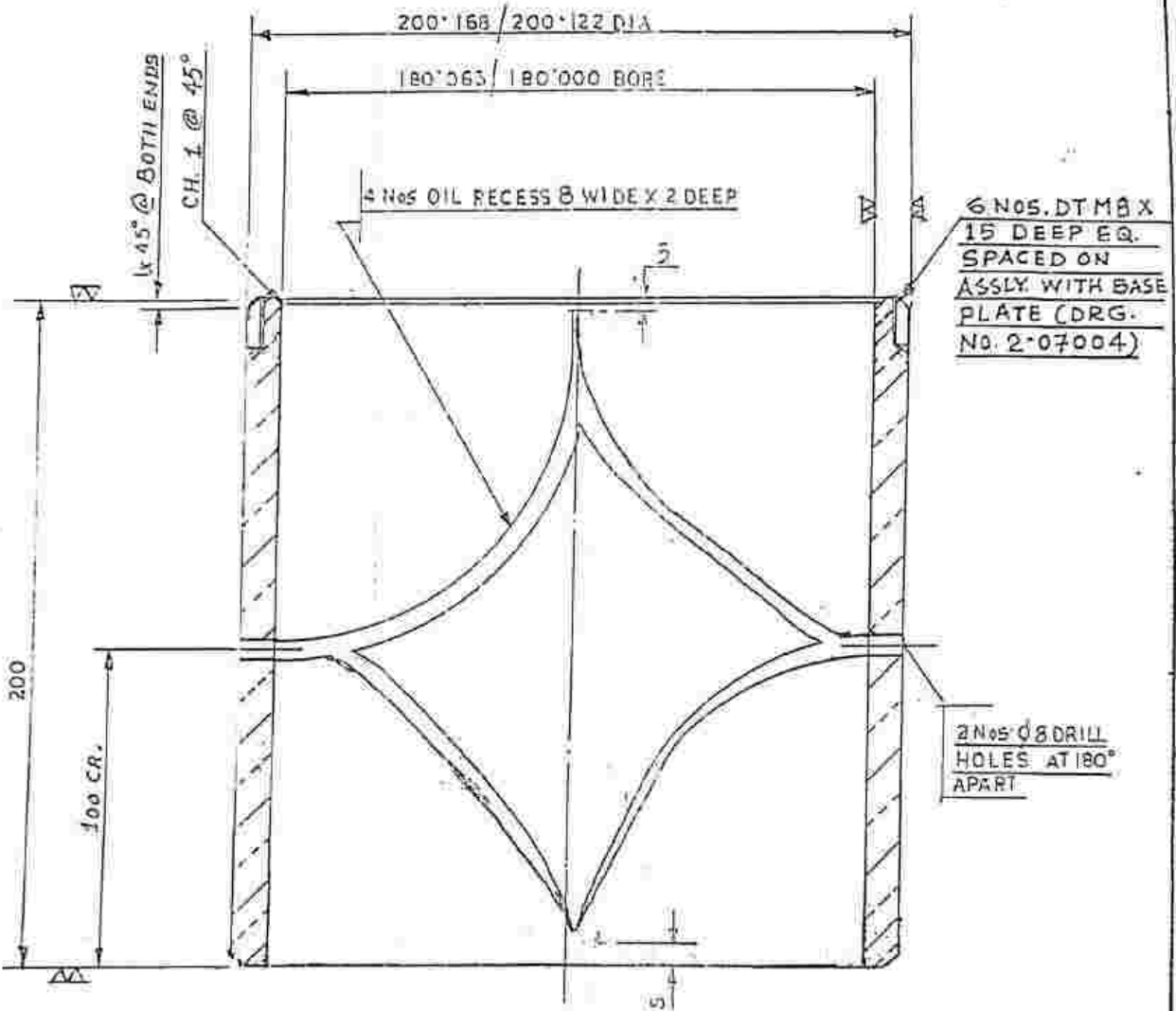

	BUSH			1560.00.002	
				MATERIAL - G1C B.S. 1400	
	BUFEAU-CHIEF	VIKASH KUMAR	<i>(Signature)</i>	SCALE: 1:2	WEIGHT IN KG. 10.00
	CHECKED BY	VIKASH KUMAR	<i>(Signature)</i>	H.M.B. HEC LTD., RANCHI	Nov. '19
1560.00.000	DESIGNED BY	NAVEEN KUMAR	<i>(Signature)</i>		Rev.-0
1560.00.200	DRAWN BY	V.S. KUMAR	<i>(Signature)</i>		
REF.DRG.NO.					

GARDEN REACH SHIPBUILDERS & ENGINEERS LTD. CALCUTTA.		DECK MACHINERY DIVISION	
DRAWN <i>A.K.</i> DATE 14.5.89	DESCRIPTION		SK No. 4.07027
TRACED	DATE	BOTTOM BUSH	REV.
CHECKED <i>(Signature)</i> DATE 2.9.88.	MATERIAL - G10. B.S. 1400		SCALE - 1:2.5
EST. WT - 8 Kgs.			

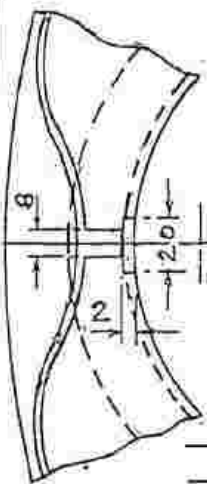
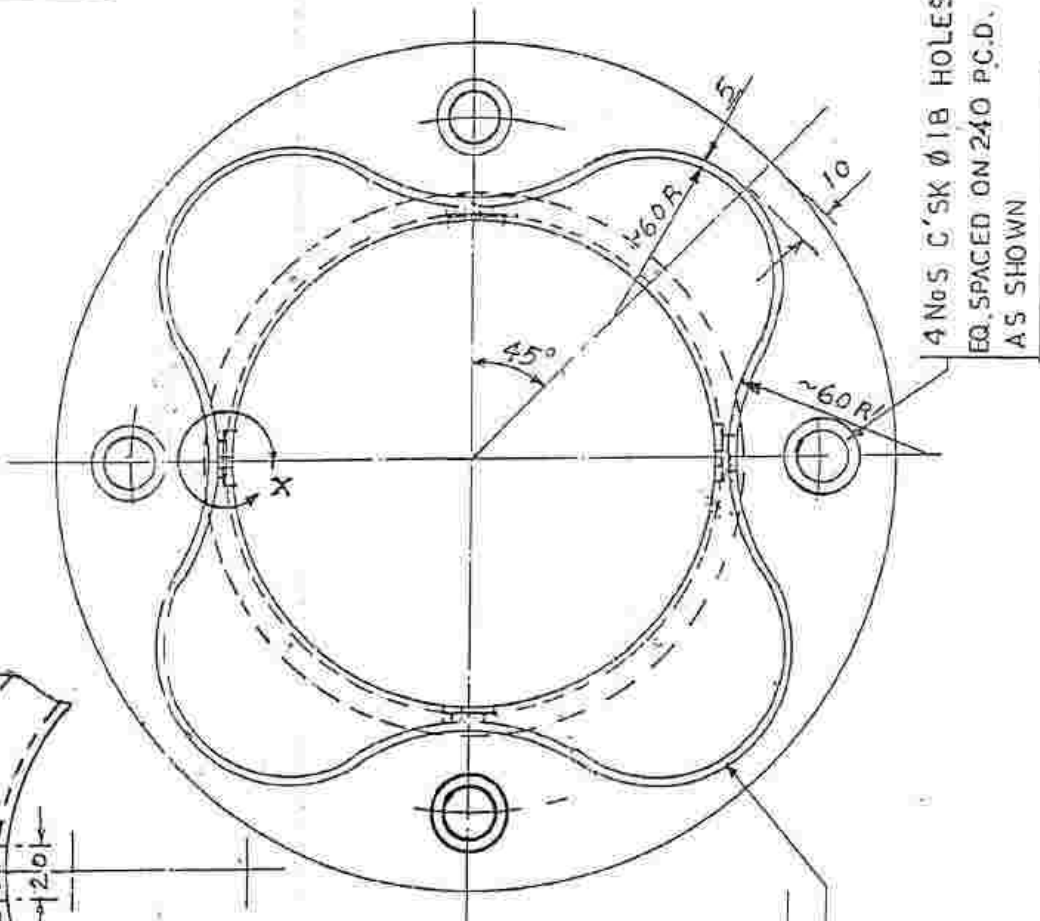
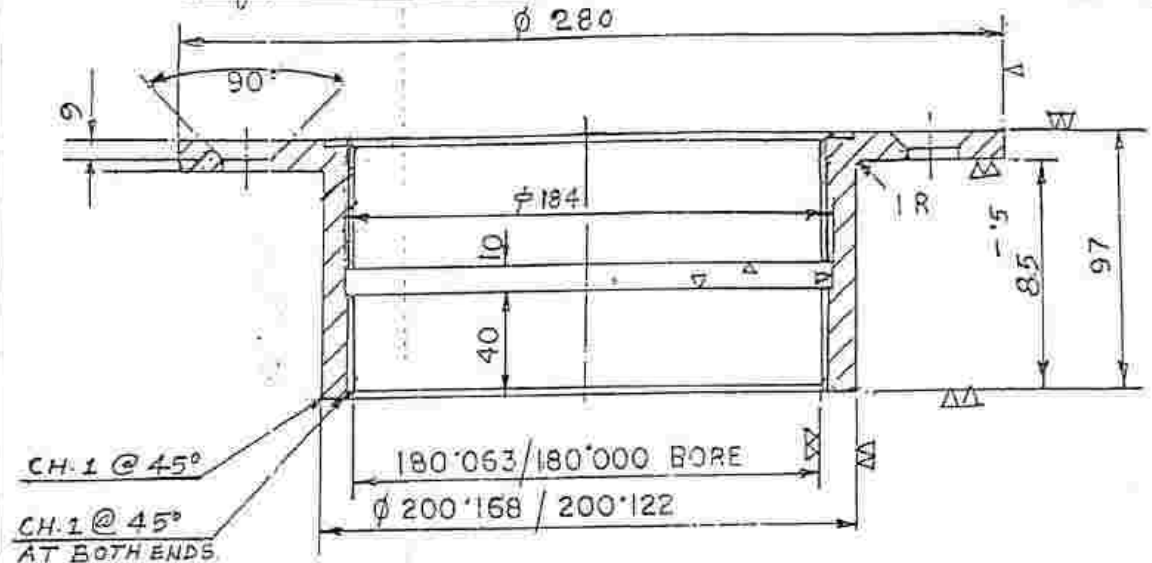

	BOTTOM BUSH		1560.00.004	
			MATERIAL G10 B.S. 1400	
BUREAU CHIEF	VIKASH KUMAR		SCALE: 1:2.5	WEIGHT IN KG - 8.00
CHECKED BY	VIKASH KUMAR		H.M.B HEC LTD., RANCHI	Nov. '19
DESIGNED BY	HAVEEN KUMAR	Rev.-0		
DRAWN BY	V.S. KUMAR			

GARDEN REACH SHIPBUILDERS & ENGINEERS LTD. CALCUTTA.		DECK MACHINERY DIVISION	
DRAWN BY: <i>[Signature]</i>	DATE: 14.5.78	DESCRIPTION	SK No. 407028
TRACED	DATE	TOP BUSH	REV.
CHECKED: <i>[Signature]</i>	DATE: 2.9.78	MATERIAL - G1C BS 1400	SCALE - 1:2.5
EST. WT - 8 Kgs			

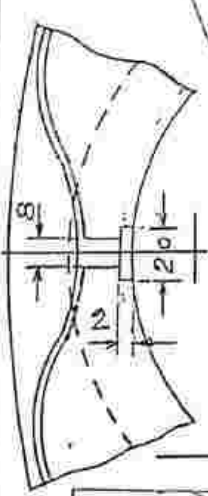
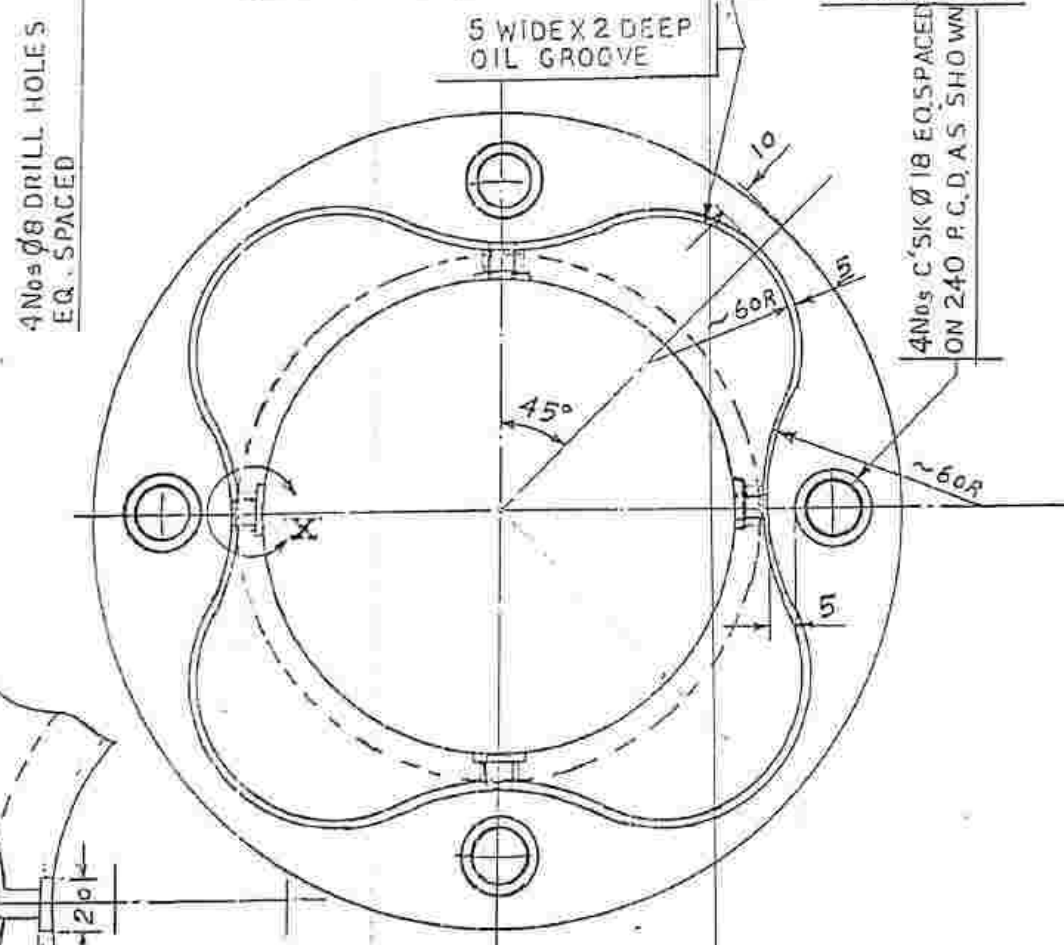
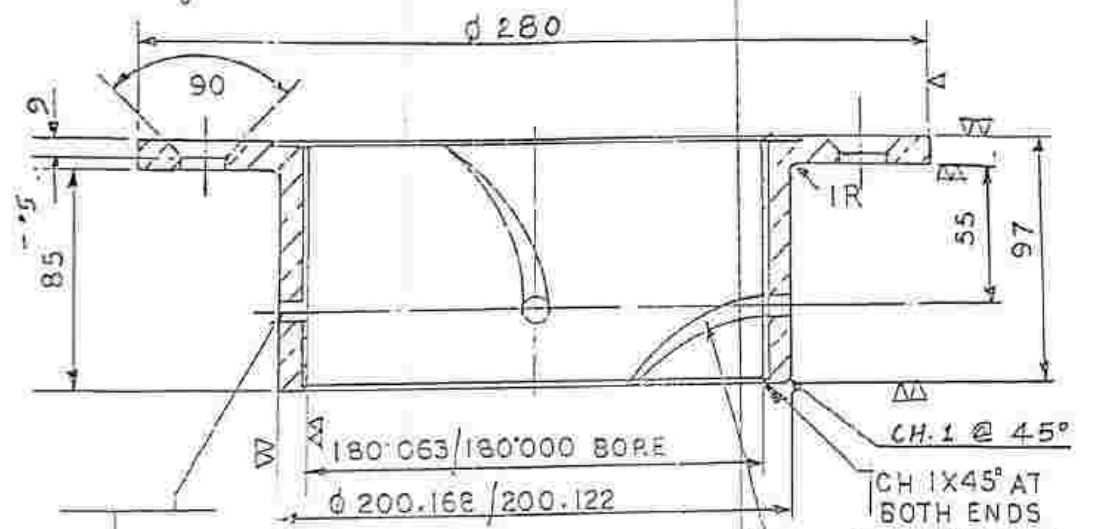

DETAIL AT X
(TYPICAL)

	TOP BUSH		1560.00.005	
			MATERIAL - G1C B.S. 1400	
1560.00.000	BUREAU ENGINEER	VIKASH KUMAR	SCALE: 1:2.5	WEIGHT IN KG - 8.00
1560.00.200	CHECKED BY	VIKASH KUMAR	H.M.B	Nov. '19
REF DRG NO	DESIGNED BY	NAVNEE KUMAR		Rev-0
	DRAWN BY	V.S. KUMAR	HEC LTD. RANCHI	

DRAWN *A.K. Indrajit* DATE 17.5.89

DESCRIPTION

SK No. 4.07030

TRACED DATE

BARREL BUSH

REV. | | | | |

CHECKED *[Signature]* DATE 27.9.88

MATERIAL— B.S. 1400-G1-C

SCALE— 1:2.5

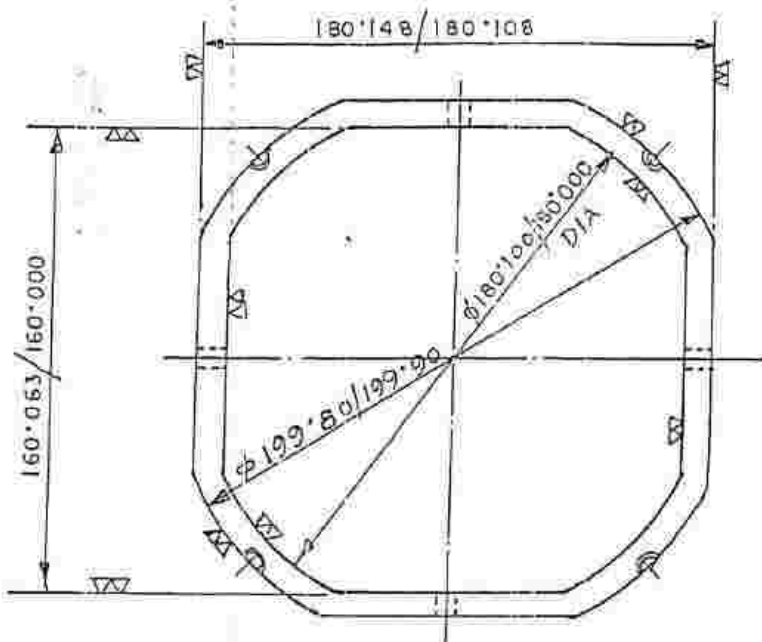

EST. WT— 12 Kgs.

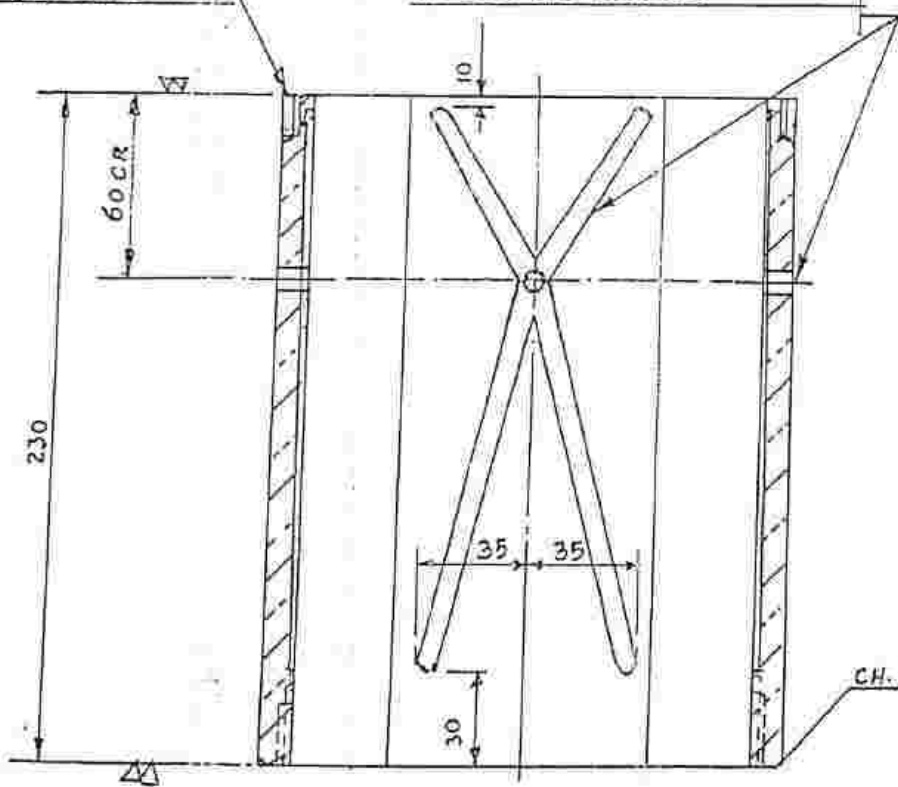

4 NOS. DT. M8 X
15 DEEP TO BE
MADE WITH WARPING
HEAD (DRG. NO. 2.07005)

4 Nos ϕ 6 DRILL HOLES AND 3 WIDE
X 1 DEEP OIL GROOVES



	BARREL BUSH		1560.00.007		
			G1C MATERIAL— B.S. 1400		
	BUREAU CHIEF	VIKASH KUMAR		SCALE: 1:2.5	WEIGHT IN KG - 12.00
1560.00.000	CHECKED BY	VIKASH KUMAR			H.M.B
1560.00.200	DESIGNED BY	NAVEEN KUMAR	HEC LTD. RANCHI		Nov. '19
REF. DRG. NO.	DRAWN BY	V.S. KUMAR			Rev.-0

1560.00.0951

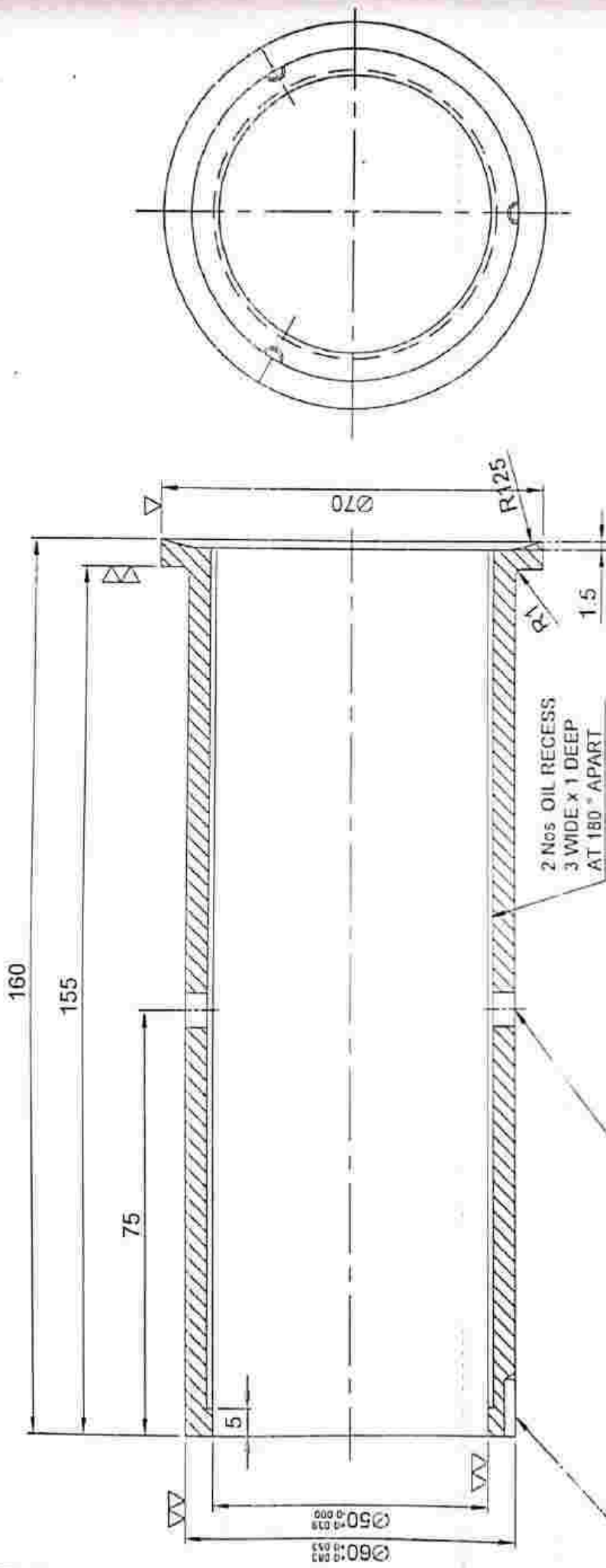

1560.00.026

BUSH

एच. ई. सी.



5.07075	BUREAU CHIEF	VIKASH KUMAR	SCALE-1:1	WEIGHT IN KG.-	1.50
	CHECKED BY	VIKASH KUMAR		MATERIAL-	GIC. BS:1400
1560.00.000	DESIGNED BY	NAVEEN KUMAR		H.M.B.	
1560.00.200	DRAWN BY	V.S. KUMAR		Nov. '19	
REF DRG. NO.				HEC LTD., RANCHI	
				Rev.-0	

DRAWN *[Signature]* DATE 19.5.88

DESCRIPTION

SK No. 4.07024

TRACED DATE

BUSH (2-HALVES)

REV.

CHECKED *[Signature]* DATE 27.9.88

MATERIAL - B.S. 1400 G.C.

SCALE - 1:1

EST. WT - 1 Kg.

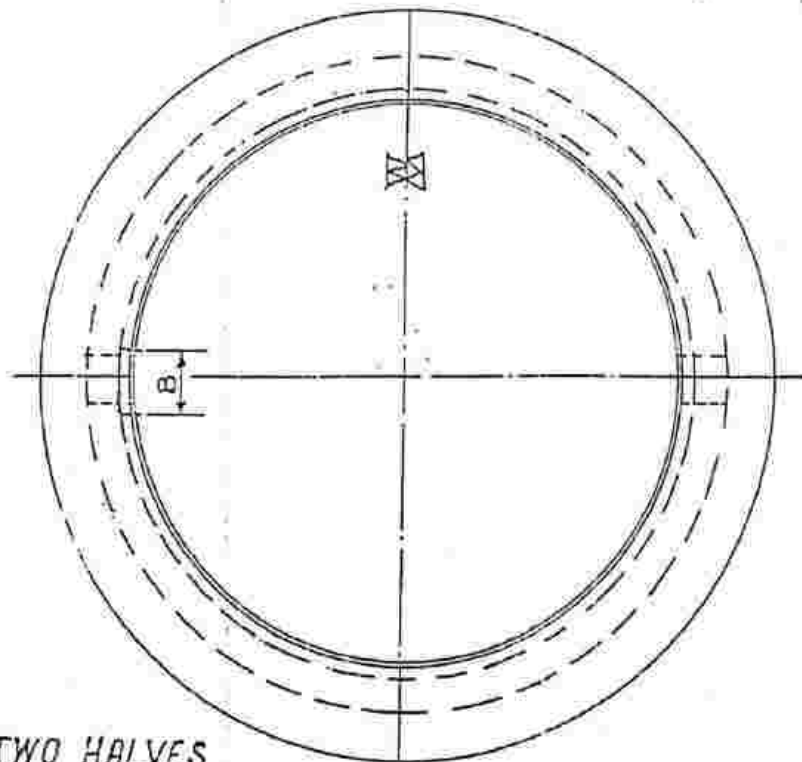
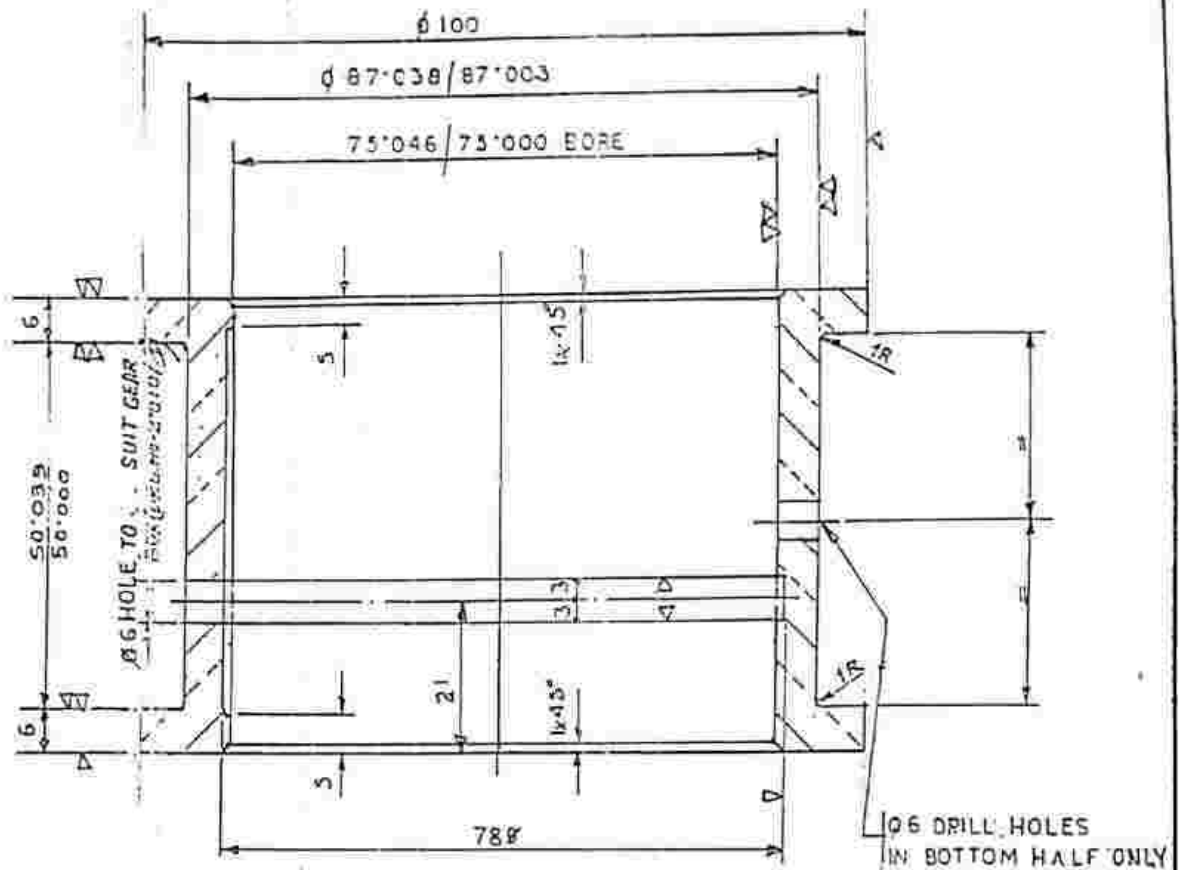

SPLIT IN TWO HALVES

	<p>BUSH (2-HALVES)</p>		<p>1560.00.042</p>	
			<p>MATERIAL - G.C. B.S. 1400</p>	
<p>1560.00.000</p>	<p>BUREAU CHIEF VIKASH KUMAR</p>	<p>CHECKED BY VIKASH KUMAR</p>	<p>SCALE - 1:1</p>	<p>WEIGHT IN KG. - 1.00</p>
<p>1560.00.200</p>	<p>DESIGNED BY NAVEEN KUMAR</p>	<p>DRAWN BY V.S. KUMAR</p>	<p>H.M.B</p>	<p>Nov. '19</p>
<p>REF DRG NO</p>			<p>HEC LTD RANCHI</p>	<p>Rev.-0</p>

DRAWN *Prady* DATE 19.5.88

DESCRIPTION

SK No. 4..07035

TRACED DATE

BUSH (2 HALVES)

REV.

CHECKED *(Or)* DATE 27.9.89

MATERIAL - B.S. 1400-G1-C

SCALE - 1:1

EST. WT - 0.8 Kg.

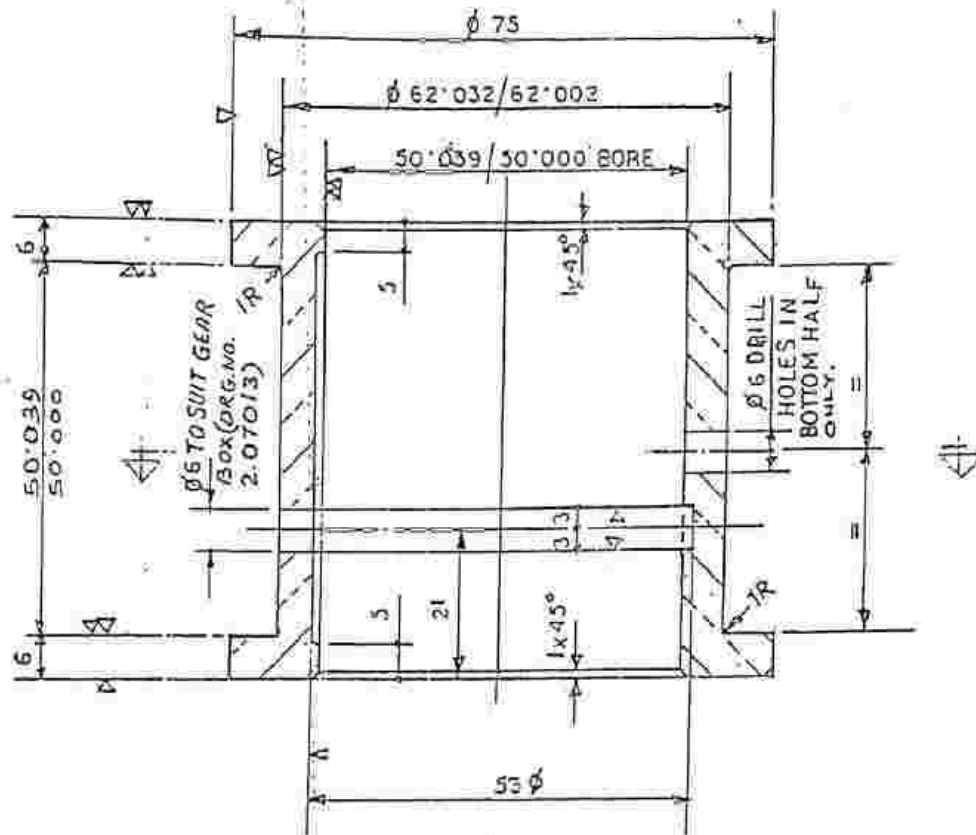

SPLIT IN TWO HALVES



BUSH (2 HALVES)

1560.00.043

MATERIAL - G1C B.S. 1400

1560.00.000	BUREAU-CHIEF	VIKASH KUMAR	<i>(Signature)</i>	SCALE-1:1	WEIGHT IN KG.- 0.80
1560.00.091	CHECKED BY	VIKASH KUMAR			
1560.00.200	DESIGNED BY	NAVEEN KUMAR	<i>(Signature)</i>	H.M.E.	Nov. '19
REF.DRG.NO.	DRAWN BY	V.S. KUMAR			HEC LTD., RANCHI

GARDEN REACH SHIPBUILDERS & ENGINEERS LTD. CALCUTTA.

DECK MACHINERY DIVISION

DRAWN *K. Sanyal* DATE 23.5.88

TRACED DATE

CHECKED *(Signature)* DATE 27.9.88

EST. WT - 0.5 Kg.

DESCRIPTION

B U S H

MATERIAL - B S 1400-G1-C

SK No. 5.07079

REV.

SCALE - 1:1

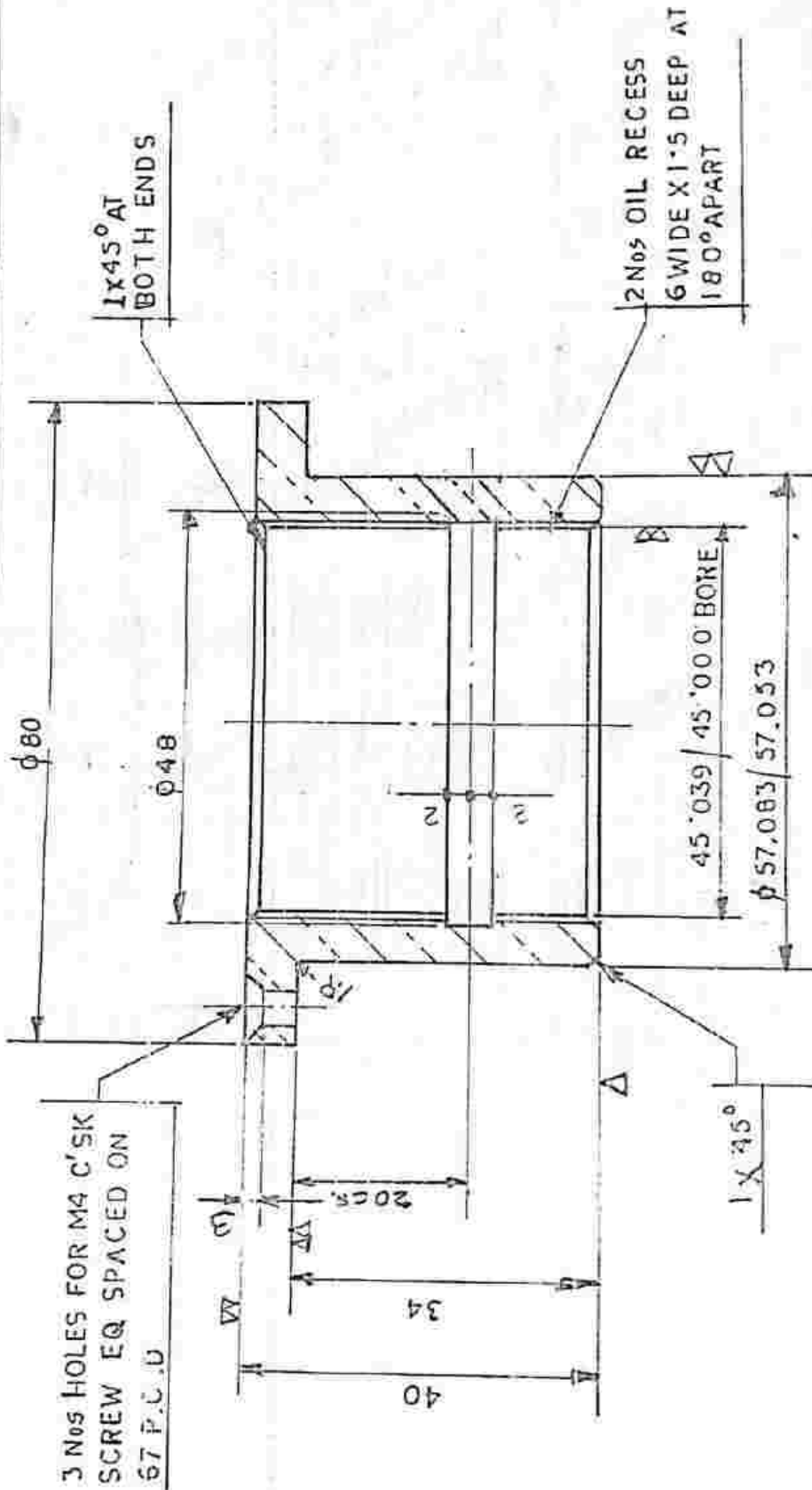

DATE 23.5.88



B U S H

1560.00.047

MATERIAL - BS1400
WEIGHT IN KG - 0.50

DESIGNER - H.M.B

NOV. '18

HECK LTD RANCHI

DESIGNED BY	VIKASH KUMAR
CHECKED BY	VIKASH KUMAR
APPROVED BY	HAUSEN KUMAR
DATE	27.9.88

1560.00.000

REF DES NO

1560.00.102

GARDEN REACH SHIPBUILDERS & ENGINEERS LTD., KOLKATA		DECK MACHINERY DIVISION	DRAWING NO. 4.07192
DRAWN BY R. Chakraborty	DATE 30.08.16	BUSH	YARD NO. MDL P 15 A.
TRACED BY	DATE		REV. A
CHECKED BY	DATE		REV. B
APPROVED BY	DATE		REV. C
EST. WT. 10 Kgs.	SCALE 1:2	MATERIAL G1C B.S. 1400	

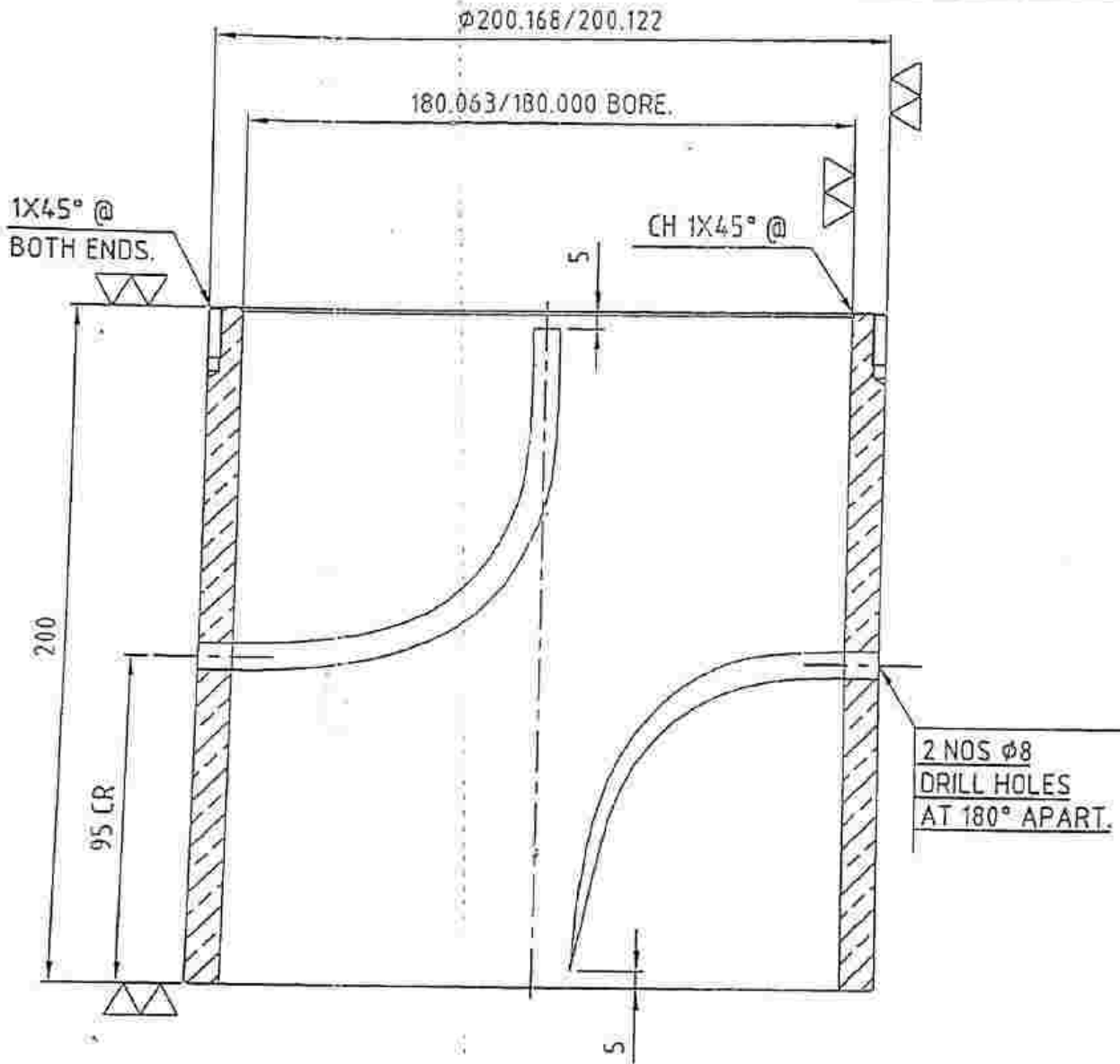

	BUSH		1560.00.102	
			MATERIAL- G1C E.S. 1400	
	BUREAU-CHIEF	VIKASH KUMAR	SCALE-1:2	WEIGHT IN KG.- 10.00
	CHECKED BY	VIKASH KUMAR	H.M.B. HEC LTD., RANCHI	
	DESIGNED BY	NAVEEN KUMAR		
1560.00.100	DRAWN BY	V.G. KUMAR	Rev.-0	
REF.DRG.NO.				

QS/70/0004 REV. 01 UNSPECIFIED TOLERANCES AS PER IS 2102 UNLESS STATED OTHERWISE. A 4

1560.00.104

GARDEN REACH SHIPBUILDERS & ENGINEERS LTD., KOLKATA, DECK MACHINERY DIVISION		DRAWING NO.	4.07193	
DRAWN BY R. Chakraborty DATE 30.09.05		YARD NO.	MDL P 15 A	
TRACED BY	DATE	REV.	DESCRIPTION	DATE
CHECKED BY	DATE	A		
APPROVED BY	DATE	B		
EST. WT. 8 KGS.	SCALE 1:2.5	C		

BOTTOM BUSH

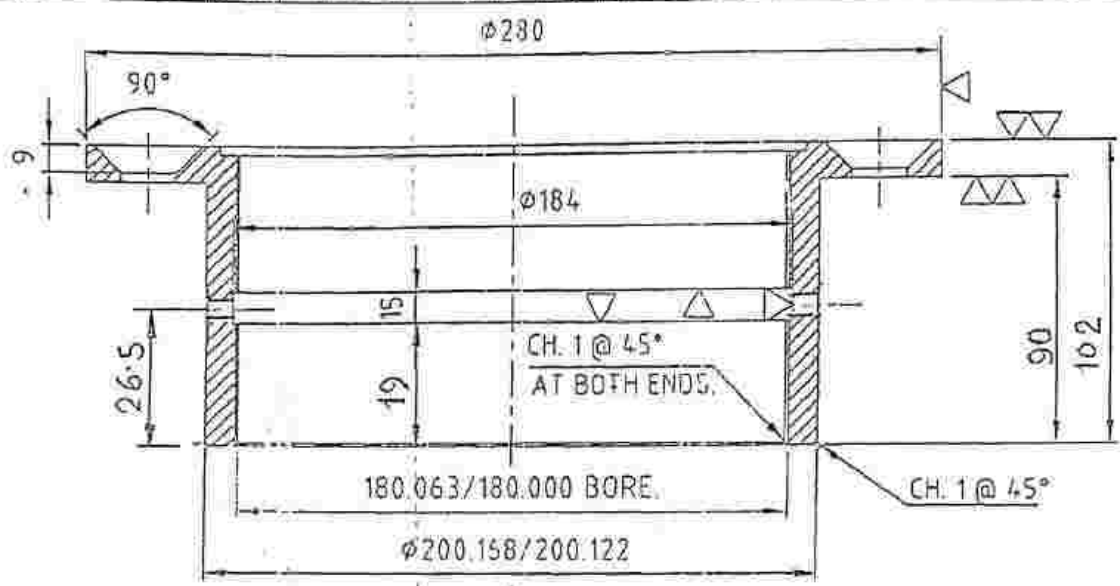

4 NOS. C'SK $\phi 18$
HOLES EQ. SPACED
ON 240 P.C.D.
AS SHOWN.

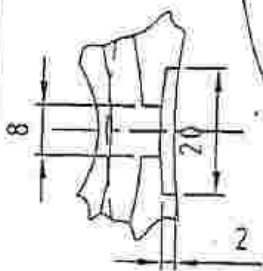
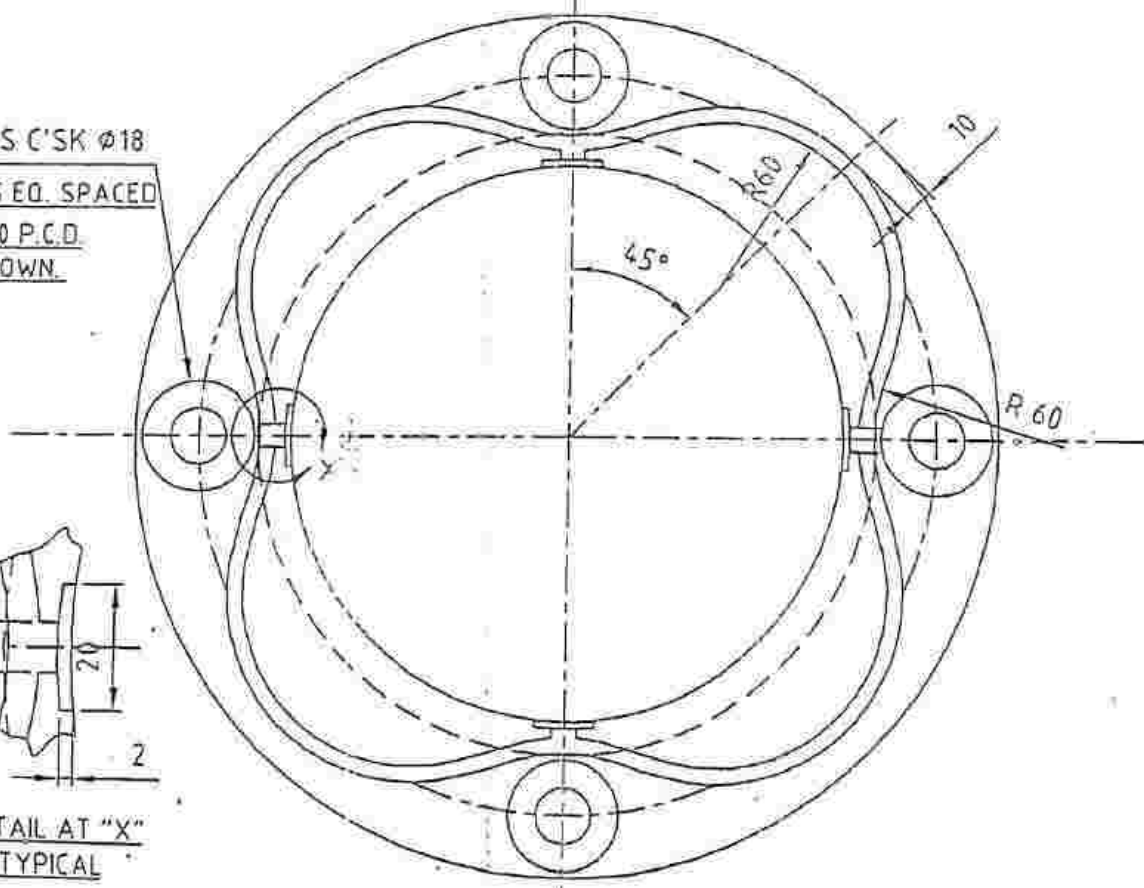

DETAIL AT "X"
TYPICAL

	<h2>BOTTOM BUSH</h2>		1560.00.104	
			MATERIAL: G1C B.S. 1400 WEIGHT IN KG. - 8.00	
BUREAU-IN-CHARGE	VIKASH KUMAR		SCALE: 1:2.5	WEIGHT IN KG. - 8.00
CHECKED BY	VIKASH KUMAR			
DESIGNED BY	NAVEEN KUMAR		H.M.B	Nov. '19
DRAWN BY	V.S. KUMAR			
1560.00.100			HEC LTD., RANCHI	Rev. - 0
REF. DRG. NO.				

1560.00.126

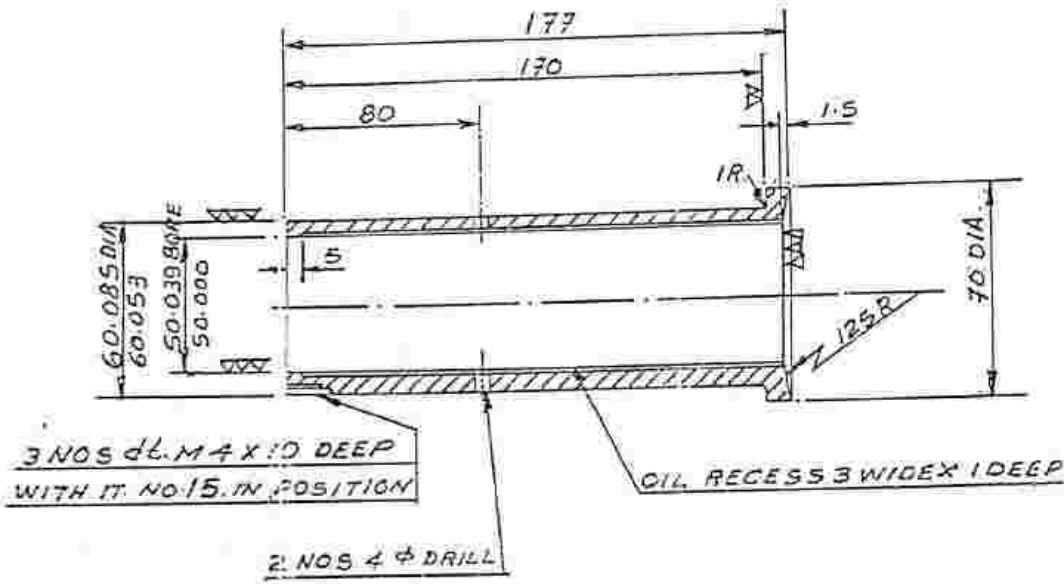

NOTE: THIS DRG IS TO BE USED AS IT NO. 26 FOR MDL HISA BRAKE SPINDLE BUSH

IT. NO	27
NO. OFF	1
MATL	B.S. 1400-G1-C
SCALE	1:2
DRG. NO.	07256611
EST. WT.	1.4 KG.

	BRAKE SPINDLE BUSH			1560.00.126	
				MATERIAL- G1C B.S. 1400 WEIGHT IN KG. 1.40	
BUREAU-CHIEF	VIKASH KUMAR		SCALE: 1:2		
CHECKED BY	VIKASH KUMAR		H.M.B. HEC LTD., RANCHI		Nov. '19 Rev.-0
DESIGNED BY	NAVEEN KUMAR				
1560.00.100	DRAWN BY	V.S. KUMAR			
REF DRG. NO.					

1560.00.132

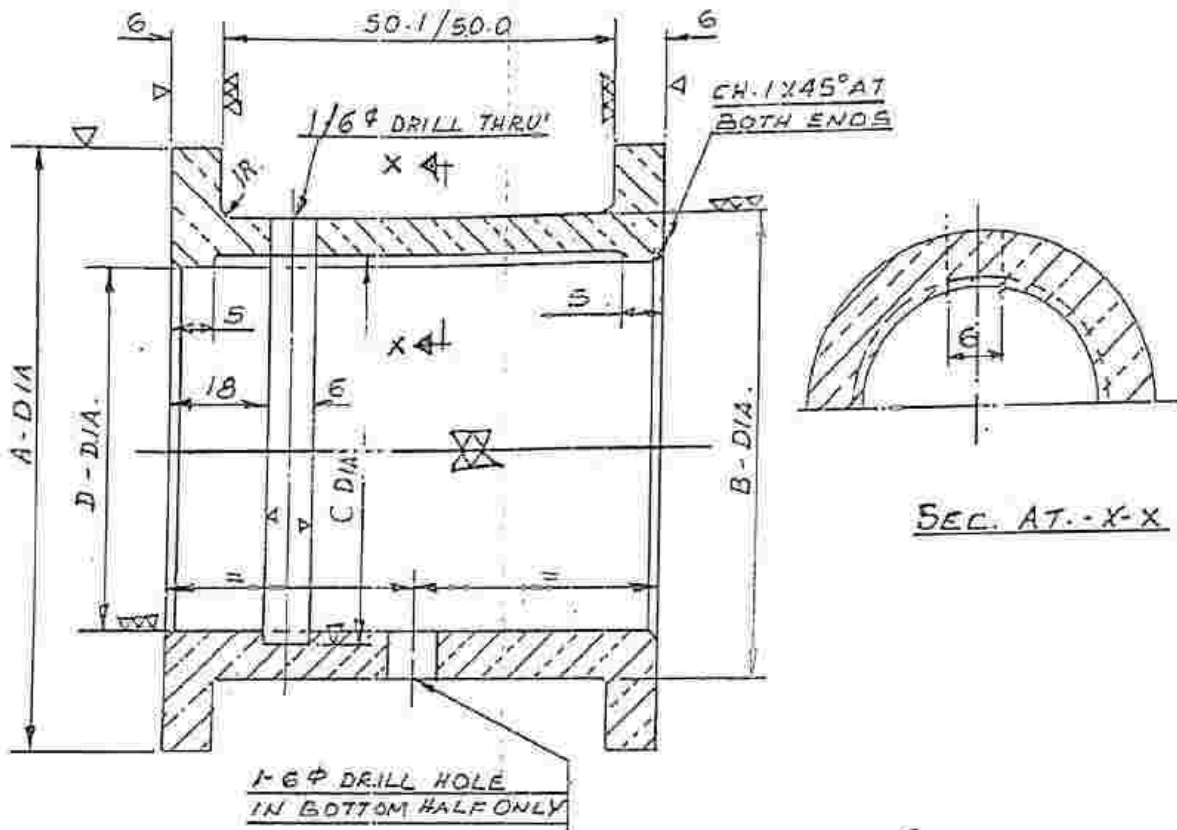

BUSH (SPLIT INTO TWO HALVES)
MATL - B.S. 1400-GI-C.
DRG. NO. 07256611

100	87.038/87.003	7B	75.046/75.000	1 KG.
A-DIA.	B-DIA	C	D-DIA.	EST. WT.

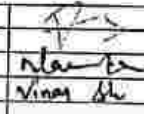
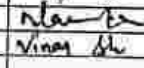
	BUSH (SPLIT)			1560.00.132	
				MATERIAL - GIC B.S. 1400	
BUREAU CHIEF	VIKASH KUMAR		SCALE: 1:2	H.M.B. HEC LTD., RANCHI	
CHECKED BY	VIKASH KUMAR				
DESIGNED BY	NAVEEN KUMAR			Rev.-0	
DRAWN BY	V.S. KUMAR				
1560.00.100					
REF DRG. NO					

1560.00.133

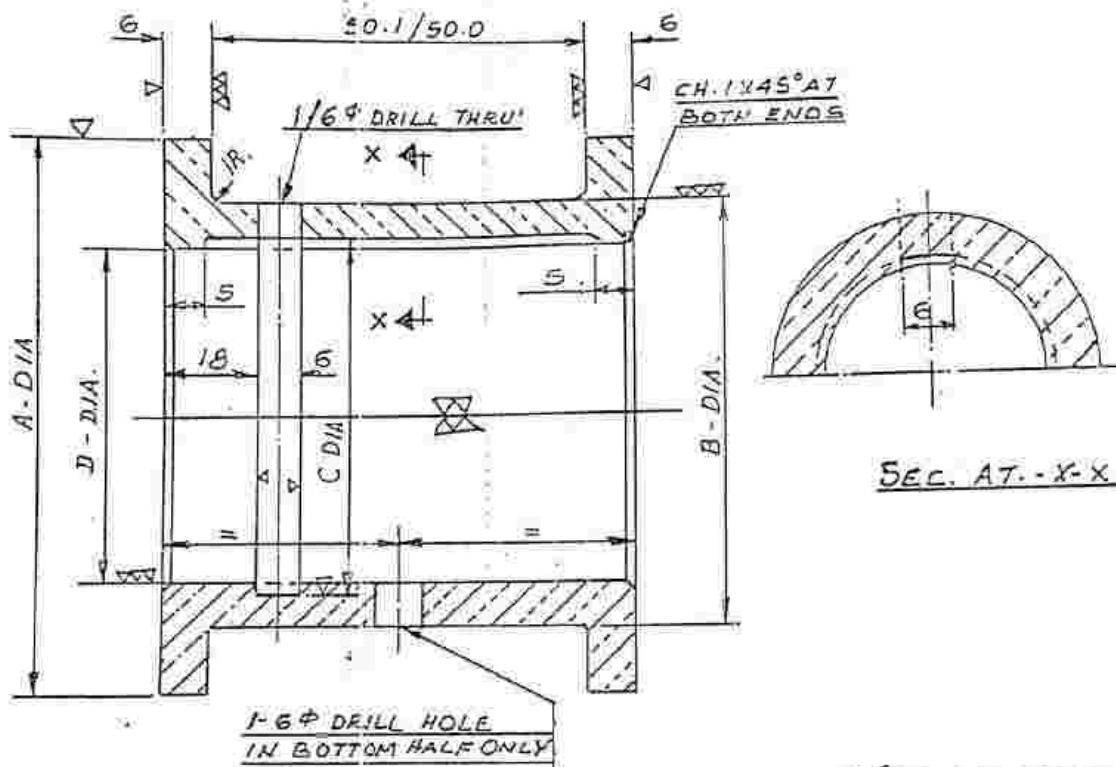

BUSH (SPLIT INTO TWO HALVES)
 MATL - B.S. 1400 G1 C
 DRG. NO. 07256611

75	62.032/62.002	53	50.039/50.000	0.7 KG
A-DIA.	B-DIA	C	D-DIA.	EST. WT.

	BUSH (SPLIT)			1560.00.133	
				MATERIAL - G1 C B.S. 1400	
BUREAU-CHIEF	VIKASH KUMAR	<i>[Signature]</i>	SCALE: 1:2	WEIGHT IN KG - 0.70	
CHECKED BY	VIKASH KUMAR	<i>[Signature]</i>	H.M.E. HEC LTD. RANCHI		
DESIGNED BY	NAVEEN KUMAR	<i>[Signature]</i>			
DRAWN BY	V.S. KUMAR	<i>[Signature]</i>			
1560.00.100				Nov. '19	
REF DRG NO				Rev.-0	

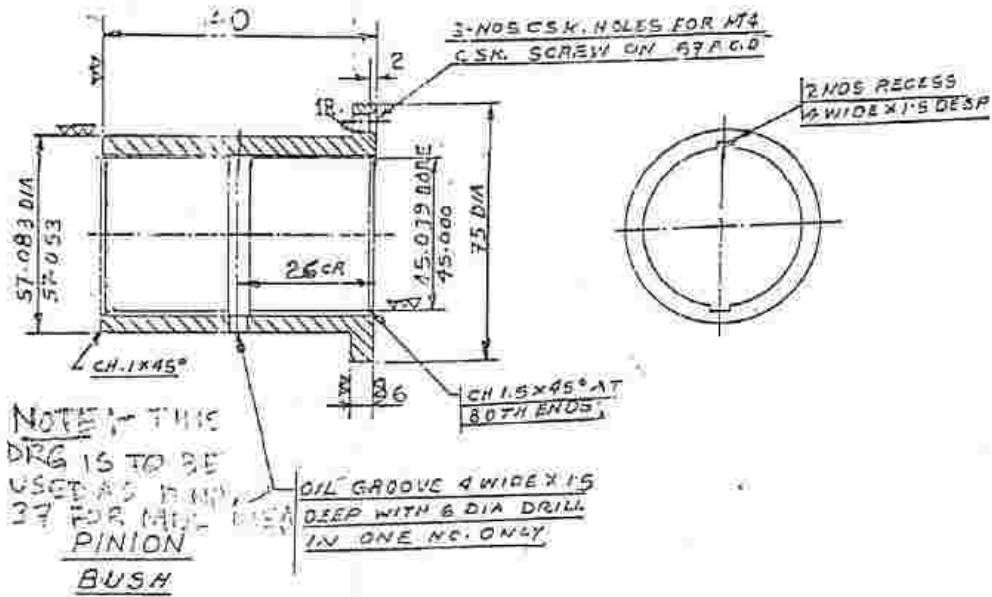

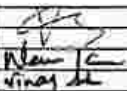
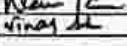

ITEM NO	38
NO. OFF	2
MATL	BS 1400-GI-C
SCALE	-
DRG. NO.	07256611
EST. WT.	0.5 KG.

	PINION BUSH		1560.00.137	
			MATERIAL: 01C B.S. 1400 WEIGHT IN KG. = 0.50	
BUREAU CHIEF	VIRASH KUMAR		SCALE: 1:2 H.M.B HEC LTD, RANCHI	
CHECKED BY	VIKASH KUMAR			
DESIGNED BY	NAVEEN KUMAR		Nov. '19 Rev:-0	
1560.00.100 REF DRG NO	DRAYIN BY V.S. KUMAR			

1560.00.301

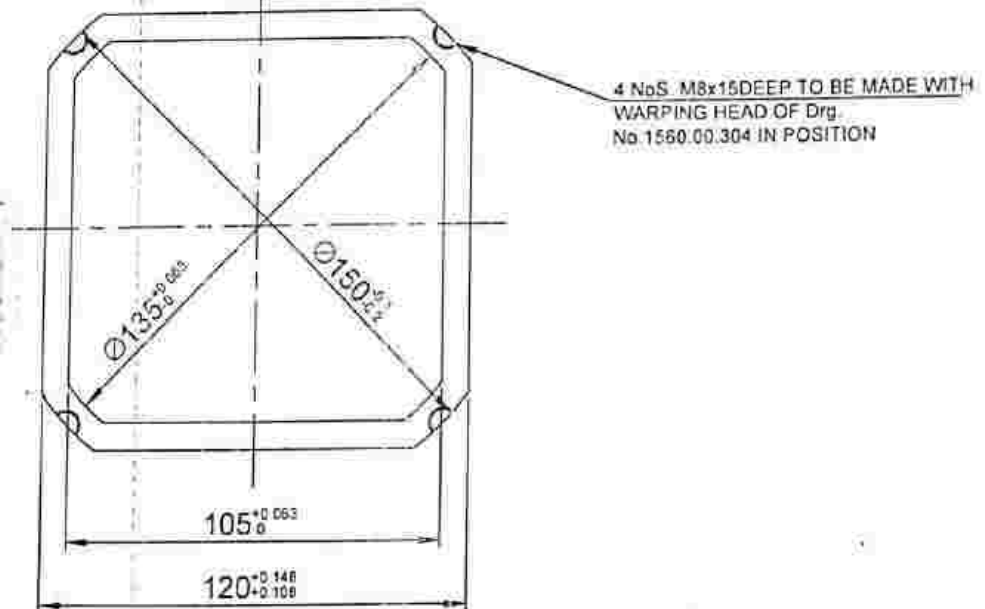
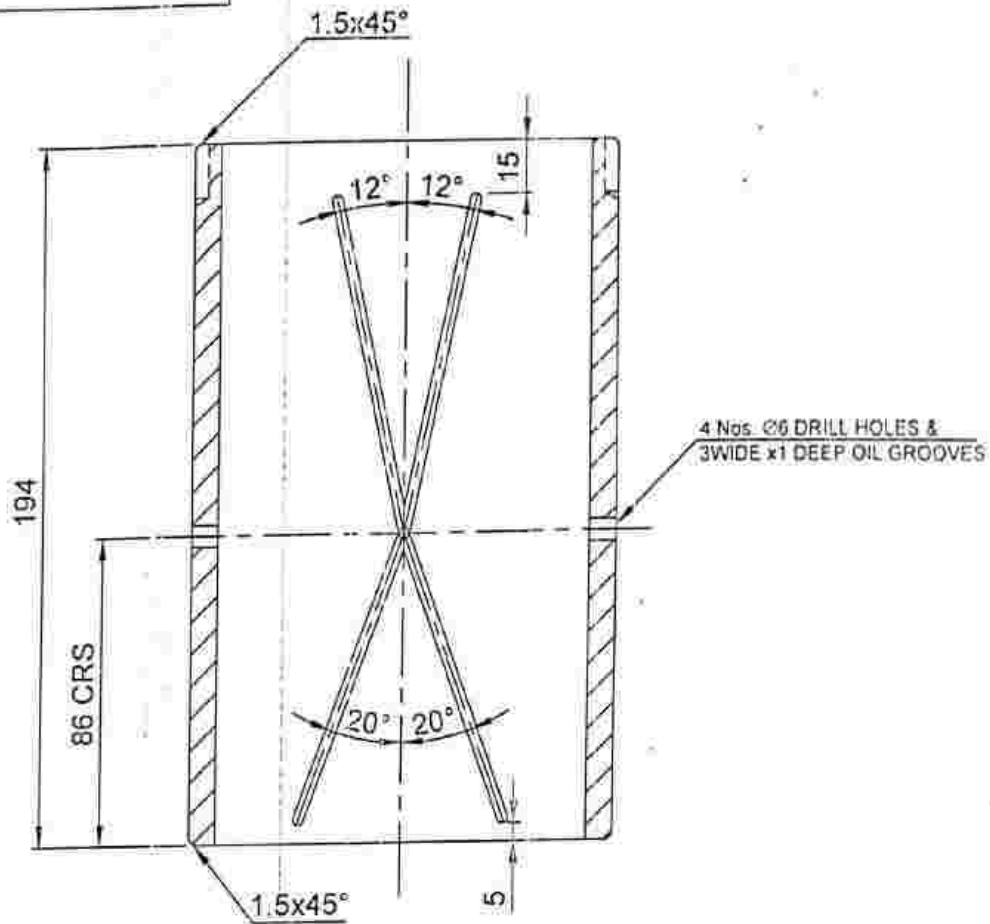
3.2
ALL OVER



 एच. ई. सी.	BARREL BUSH			1560:00.301		
				MATERIAL: LG-4C BS-1400		
4.07260	BUREAU CHIEF	VIKASH KUMAR	 SCALE: 1:2	WEIGHT IN KG.:- 5.00		
	CHECKED BY	VIKASH KUMAR		H.M.B.	Oct. '19	
	DESIGNED BY	NAVJEN KUMAR			HEC LTD, RANCHI	Rev.-0
1560.00.300	DRAWN BY	V.S. KUMAR				
REF.DRG.NO.						

1560.00.316

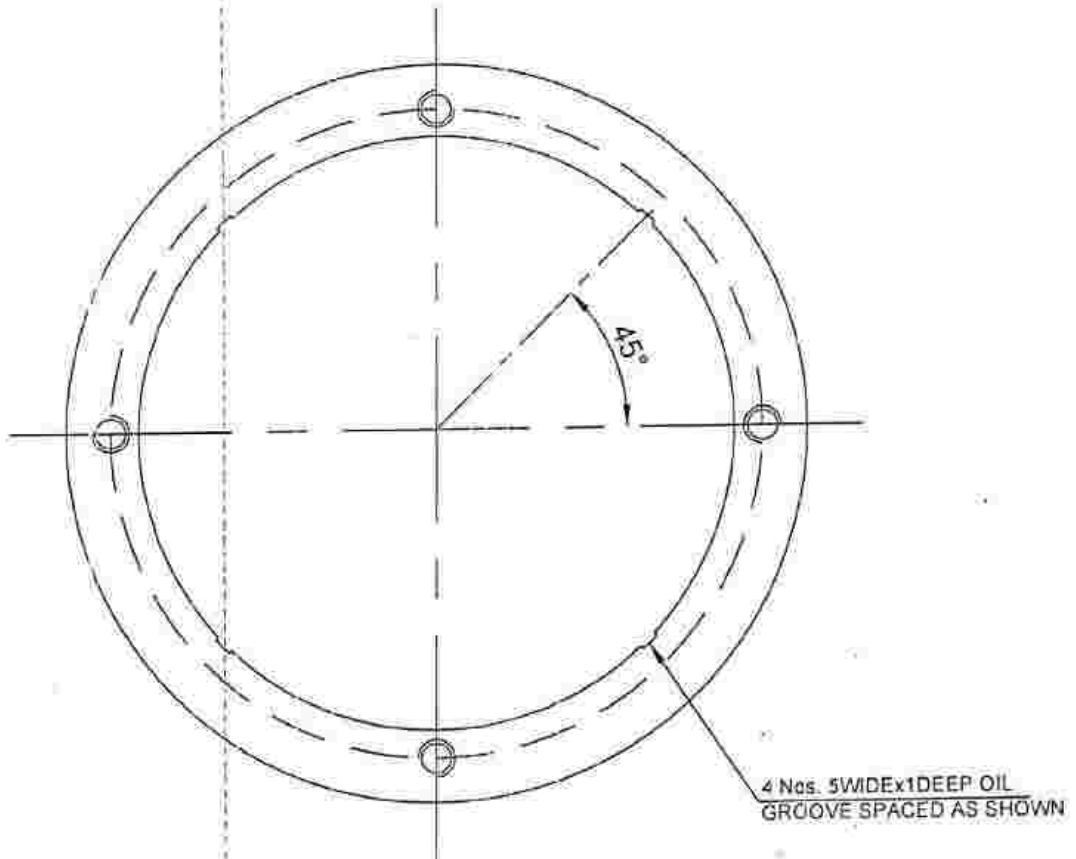
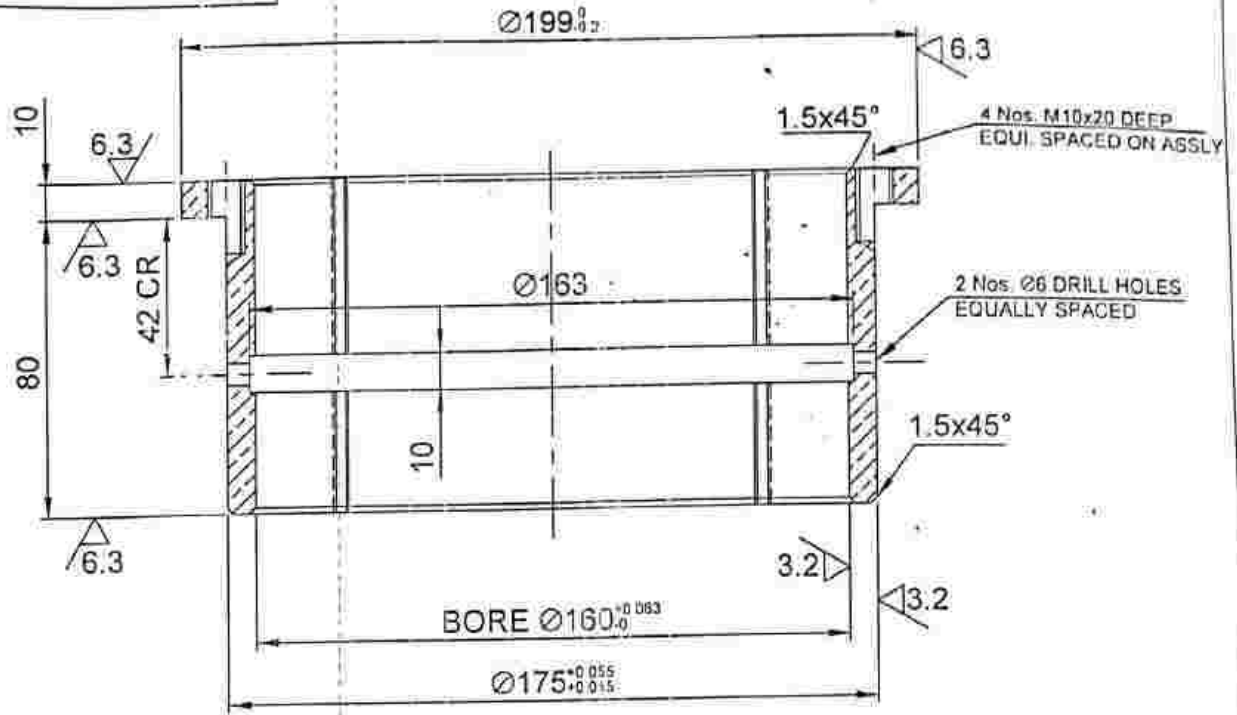

	<p>एच. ई. सी.</p>			<p>1560.00.316</p>	
	<p>TOP BUSH</p>			<p>MATERIAL: LG-4C BS:1400</p>	
4.07257	BUREAU-CHIEF	VIKASH KUMAR.	<i>[Signature]</i>	SCALE:1:2	WEIGHT IN KG.- . 3.50
	CHECKED BY	VIKASH KUMAR		<p>H.M.B.</p>	Oct. '19
	DESIGNED BY	NAVEEN KUMAR	<i>[Signature]</i>		<p>HEC LTD., RANCHI</p>
1560.00.300	DRAWN BY	V.S. KUMAR	<i>[Signature]</i>		
REF.DRG.NO.					

1560.00.317

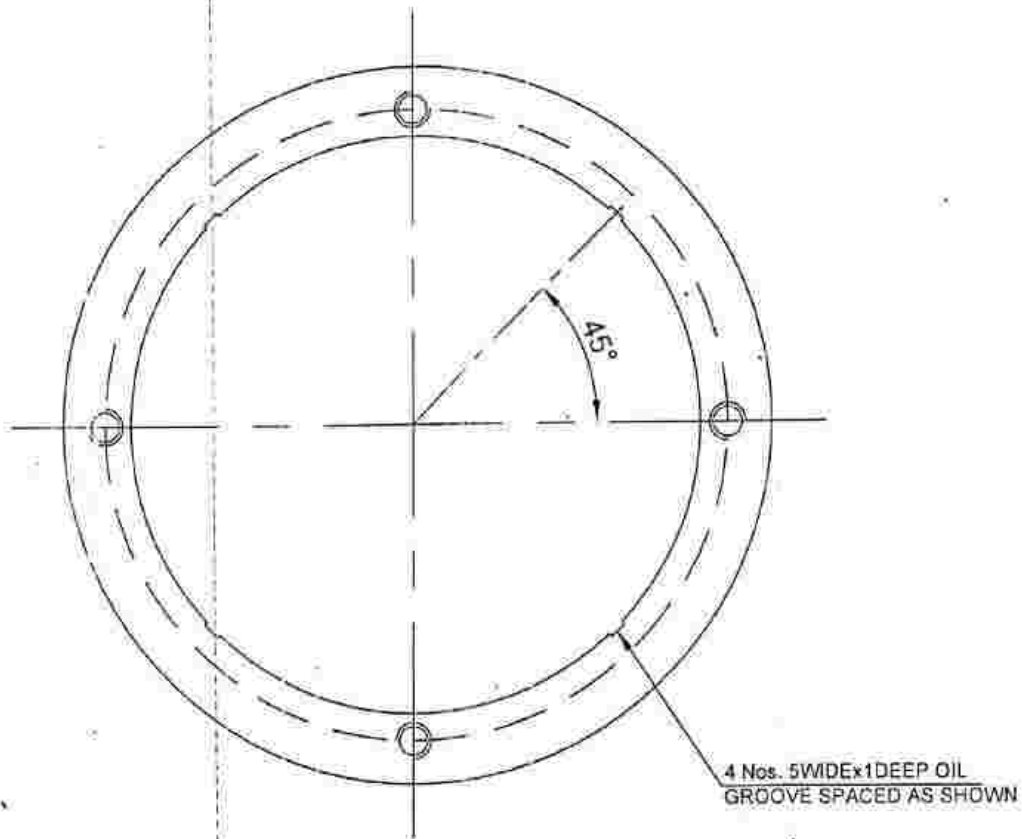
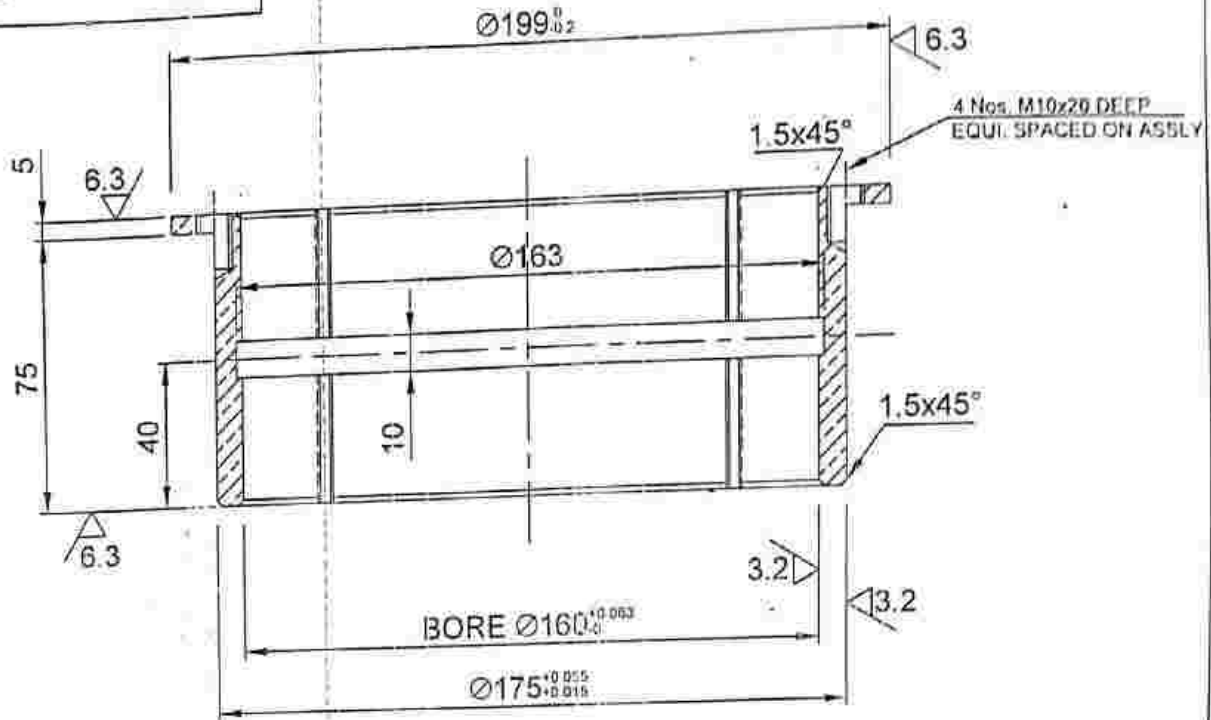

एच. ई. सी.



LOWER BUSH

1560.00.317

MATERIAL: LG-4C
BS:1400

4.07258

BUREAU CHIEF

VIKASH KUMAR

SCALE-1:2

WEIGHT IN KG.- 3.50

CHECKED BY

VIKASH KUMAR

DESIGNED BY

NAVEEN KUMAR

DRAWN BY

V.S. KUMAR

1560.00.300

REF.DRG.NO.

H.M.B.
HEC LTD., RANCHI

Oct. '19

Rev.-0

1560.00.318

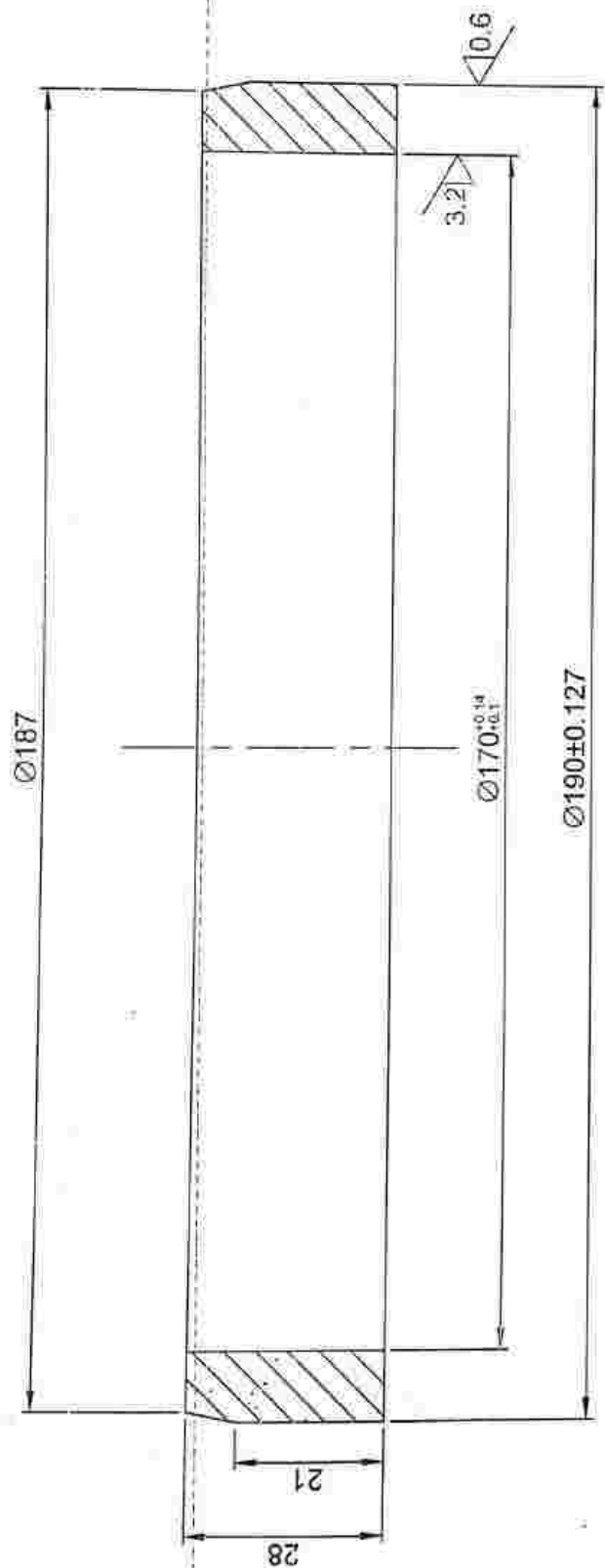

एच. ई. सी.



SPACER

1560.00.318

MATERIAL - G1C
BS:1400

SCALE: 1:1
WEIGHT IN KG - 1.50

Oct. '19

Rev.-0

BUREAU-CHIEF	VIKASH KUMAR
CHECKED BY	VIKASH KUMAR
DESIGNED BY	NAVEEN KUMAR
DRAWN BY	V.S. KUMAR

H.M.B.

HEC LTD., RANCHI

1560.00.319

3.2/  ALL OVER

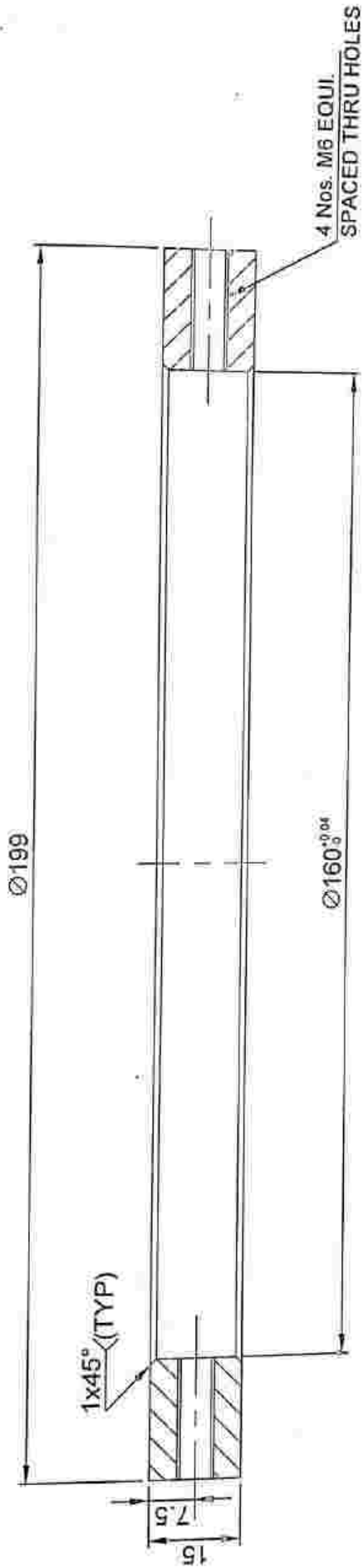

एच. ई. सी.



RING

1560.00.319

MATERIAL - LG-4C
BS:1400

SCALE-1:1 WEIGHT IN KG - 1.50

Oct. '19

Rev.-0

5.07385	BUREAU-CHIEF	VIKASH KUMAR	
	CHECKED BY	VIKASH KUMAR	
	DESIGNED BY	NAVEEN KUMAR	
1560.00.300	DRAWN BY	V.S. KUMAR	
REF.DRG.NO.			

H.M.B.

HEC LTD., RANCHI

GARDEN REACH SHIPBUILDERS & ENGINEERS LTD., KOLKATA		DECK MACHINERY DIVISION	DRAWING NO. 4.07264
DRAWN BY S. GAYEN	DATE 20.06.17	BUSH	YARD NO. 1194-96, 1203-05
TRACED BY	DATE		REV. A
CHECKED BY P. P. M	DATE 23.06.17		DESCRIPTION
APPROVED BY S. K. MOH	DATE 23.06.17		MADE
EST. WT. 0.22 KGS.	SCALE 1:1	MATERIAL LG 4C BS 1400	DATE

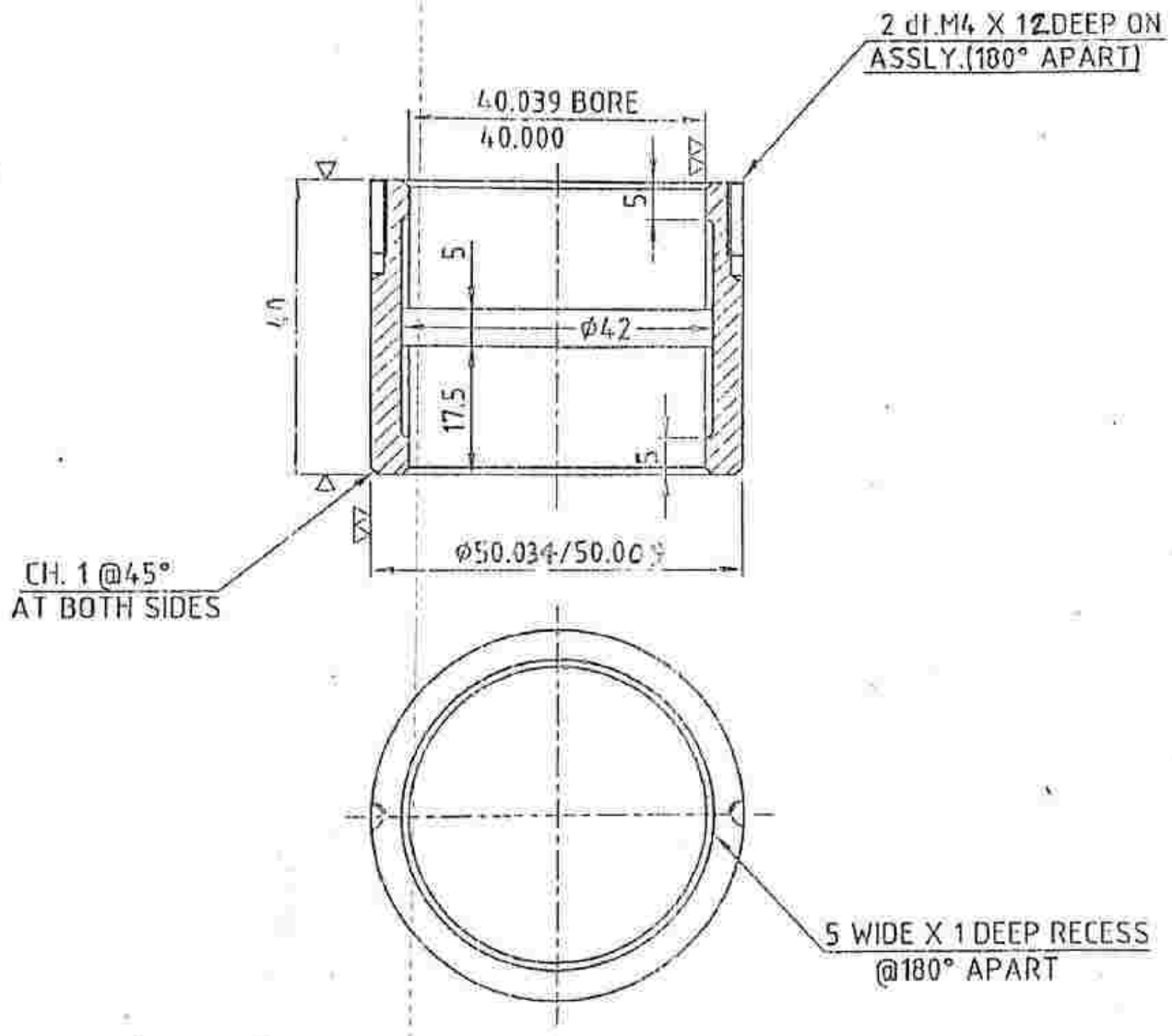

CH. 1 @ 45°
AT BOTH SIDES

2 DI. M4 X 12 DEEP ON
ASSLY. (180° APART)

5 WIDE X 1 DEEP RECESS
@ 180° APART

	BUSH		1560.00.325	
			MATERIAL LG 4C BS:1400	
BUREAU CHIEF VIKASH KUMAR			SCALE 1:1	WEIGHT IN KG. → 0.22
CHECKED BY VIKASH KUMAR			H.M.B	
DESIGNED BY NAVGEN KUMAR		Nov. '19		
DRAWN BY V.S. KUMAR		HEC LTD. RANCHI		Rev.-0
REF DRG NO. 1560.00.320				

QS/70/0004 REV. 01 UNSPECIFIED TOLERANCES AS PER IS 2102 UNLESS STATED OTHERWISE. A 4

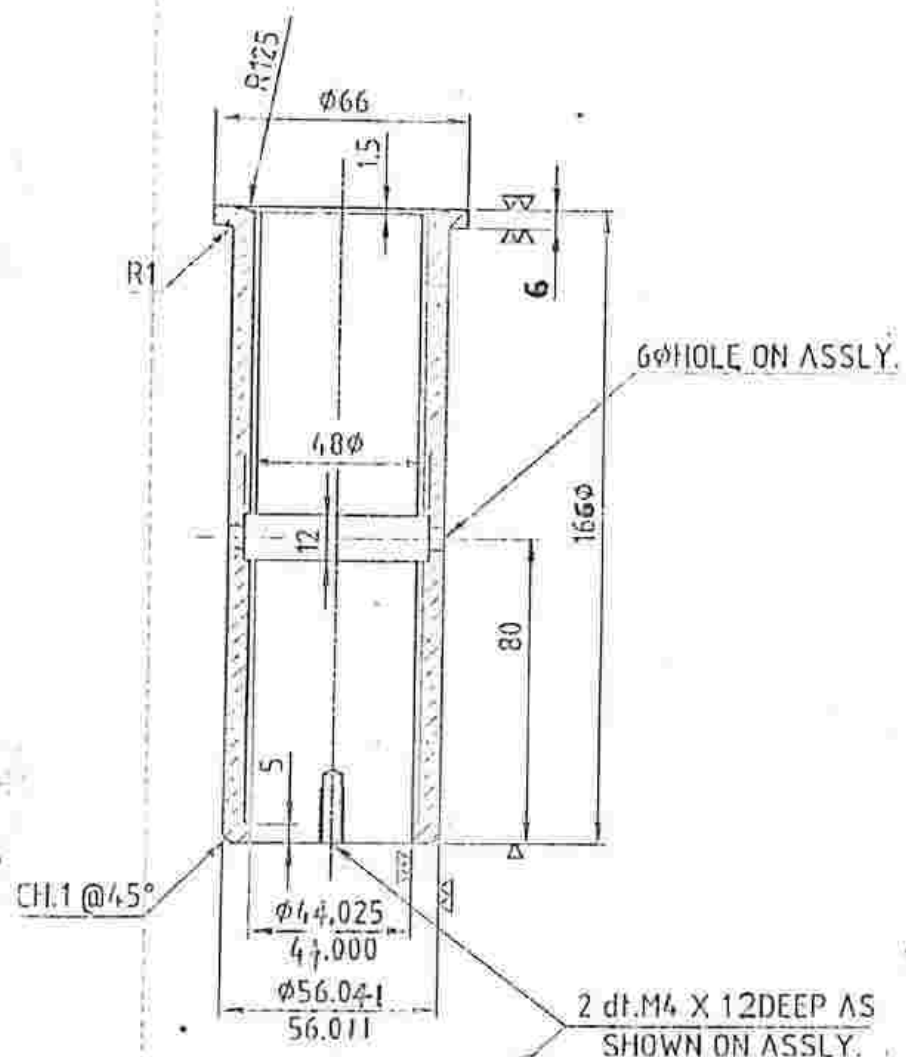

GARDEN REACH SHIPBUILDERS & ENGINEERS LTD., KOLKATA, DECK MACHINERY DIVISION		DRAWING NO. 4.07266	
DRAWN BY S. GATIN	DATE 21.01.07	YARD NO. 1194-96, 1203-05	
TRACED BY	DATE	REV. A	DESCRIPTION
CHECKED BY P. P. M.	DATE 22.11.07	REV. B	
APPROVED BY S. K. KAR	DATE 22.11.07	REV. C	
EST. WT. 1.3 KGS.	SCALE 1:1	MATERIAL LG-4C-BS 1400	

BUSH

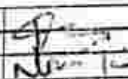

MACHINING (▽) ALL OVER

2 OIL RECESS 12 WIDE X 1.5 DEEP @ 180° APART

	BUSH		1560.00.327	
			MATERIAL LG 4C BS-1400	
		SCALE 1:1		WEIGHT IN KG. 1.30
BUREAU CHIEF	VEKASH KUMAR		H.M.P. HEC LTD. RANCHI	
CHECKED BY	VEKASH KUMAR			
DESIGNED BY	NAVEEN KUMAR		Nov. '19 Rev.-0	
DRAWN BY	S. KULIAR			
1560.00.320	REF. DRG. NO.			

QS/70/0004 REV. 01 UNSPECIFIED TOLERANCES AS PER IS 2102 UNLESS STATED OTHERWISE. A 4

GARDEN REACH SHIPBUILDERS & ENGINEERS LTD., KOLKATA, DECK MACHINERY DIVISION

DRAWING NO. 4.07267

DRAWN BY S. GAJEN DATE 23.05.07
 TRACED BY DATE
 CHECKED BY P. P. M DATE 23.05.07
 APPROVED BY S. K. KAR DATE 23.05.07
 EST. WT. ~ 4.6 kgs. SCALE 1:2

YARD NO. 1194-96.1203-05			
REV.	DESCRIPTION	MADE	DATE
A			
B			
C			

TRUNION NUT

MATERIAL GIC, B.S 1400

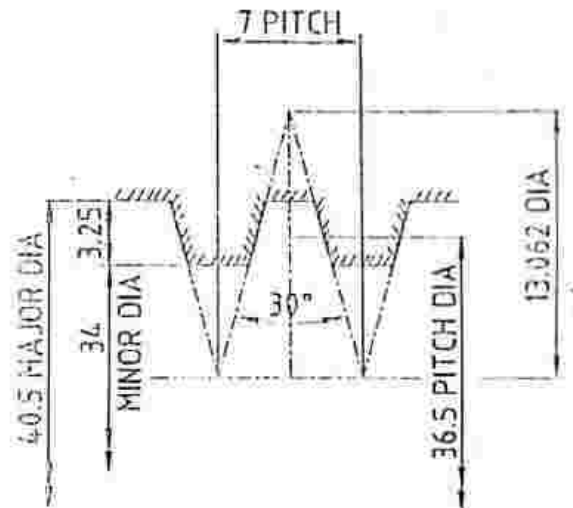
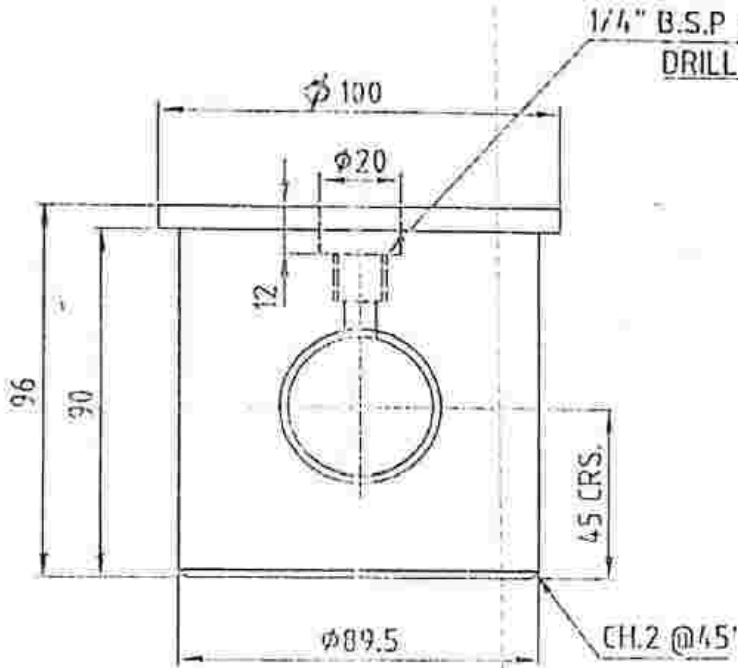

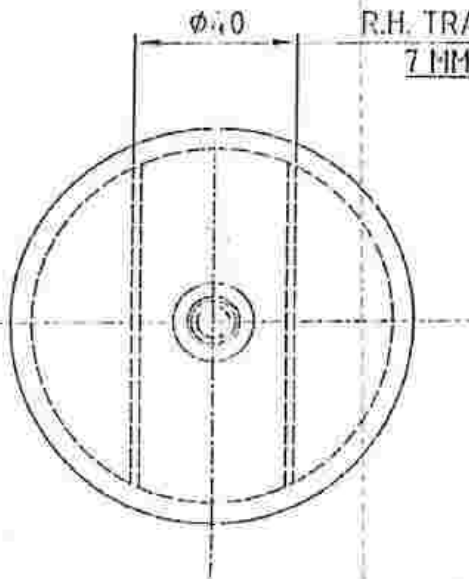

DETAIL OF TRAPEZOIDAL THREAD



R.H. TRAPEZOIDAL METRIC THREAD
 7 MM PITCH TO SUIT SPINDLE
 (DRG. NO. 1560.00.324)

▽M/CD ALL OVER

	TRUNION NUT		1560.00.328	
			MATERIAL: GIC B.S:1400	
		SCALE: 1:2		WEIGHT IN KG - 4.50
BUREAU CHIEF: NIKASH KUMAR				Nov. '19
CHECKED BY: NIKASH KUMAR				
DESIGNED BY: NAVEEN KUMAR				Rev.-0
DRAWN BY: V.S. KULJAR				
1560.00.300		H M B.		
REF. DRG. NO.		HEC LTD., RANCHI		

Q3/70/0004 REV. 01 UNSPECIFIED TOLERANCES AS PER IS 2102 UNLESS STATED OTHERWISE. A 4

GARDEN REACH SHIPBUILDERS ENGINEERS LTD., CAL., DECK MACHINERY DIVISION

DRAWN BY S.GAYEN DATE 20.01.07
 TRACED BY DATE
 CHECKED BY P. P.M. DATE
 APPROVED BY S. K. KAR DATE
 EST. WT. ~ 0.09 KG. SCALE 1:1

AWING NO. 5.07392
 YARD NO. 1194-96

REV.	DESCRIPTION	MADE DATE
A		
B		
C		

BUSH

MATERIAL LG 4C BS 1400

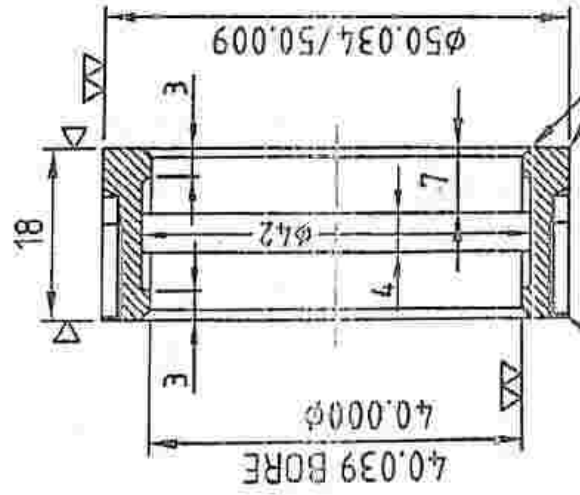

4 WIDE X 1 DEEP RECESS @180° APART

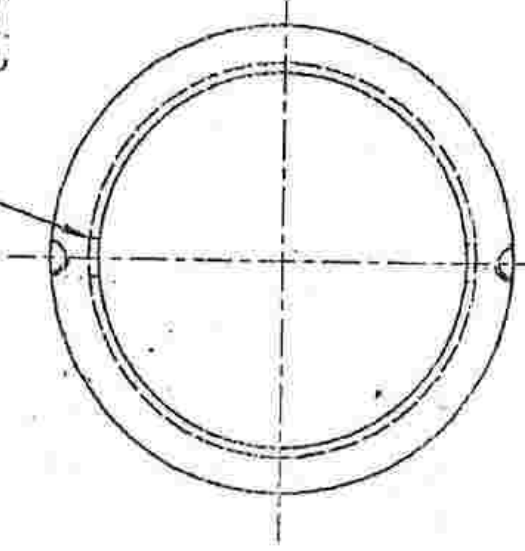

2 dt. M4 X 12 DEEP ON ASSY.
 CH. 1 @ 45° AT BOTH SIDES

		<p><u>BUSH</u></p>		<p>1560.00.333</p>	
				<p>MATERIAL - BS:1400 LG 4C WEIGHT IN KG. 0.09</p>	
<p>BUREAU-CHIEF CHECKED BY DESIGNED BY DRAWN BY</p>		<p>VIKASH KUMAR VIKASH KUMAR NAVEEN KUMAR V.S. KUMAR</p>		<p>SCALE: 1:1 H.M.B HEC LTD., RANCHI Nov. '19 Rev.-0</p>	
<p>1560.00.300 REF. DRG. NO.</p>		<p>UNSPECIFIED TOLERANCES AS PER IS 2102 UNLESS STATED OTHERWISE.</p>			

QS/70/0005 REV. 01

GARDEN REACH SHIPBUILDERS & ENGINEERS LTD., CAL., DECK MACHINERY DIVISION

DRAWN BY S.GAYEN DATE 20.03.07

TRACED BY P.P.M DATE 21.03.07

CHECKED BY S.K.KAR DATE 21.03.07

EST.WT. ~0.2 KGS. SCALE 1:1

BUSH

MATERIAL LG 4C BS 1400

DRAWING NO. 5.07402

YARD NO. 1194-96, 1203-05

REV.	DESCRIPTION	MADE DATE
A		
B		
C		

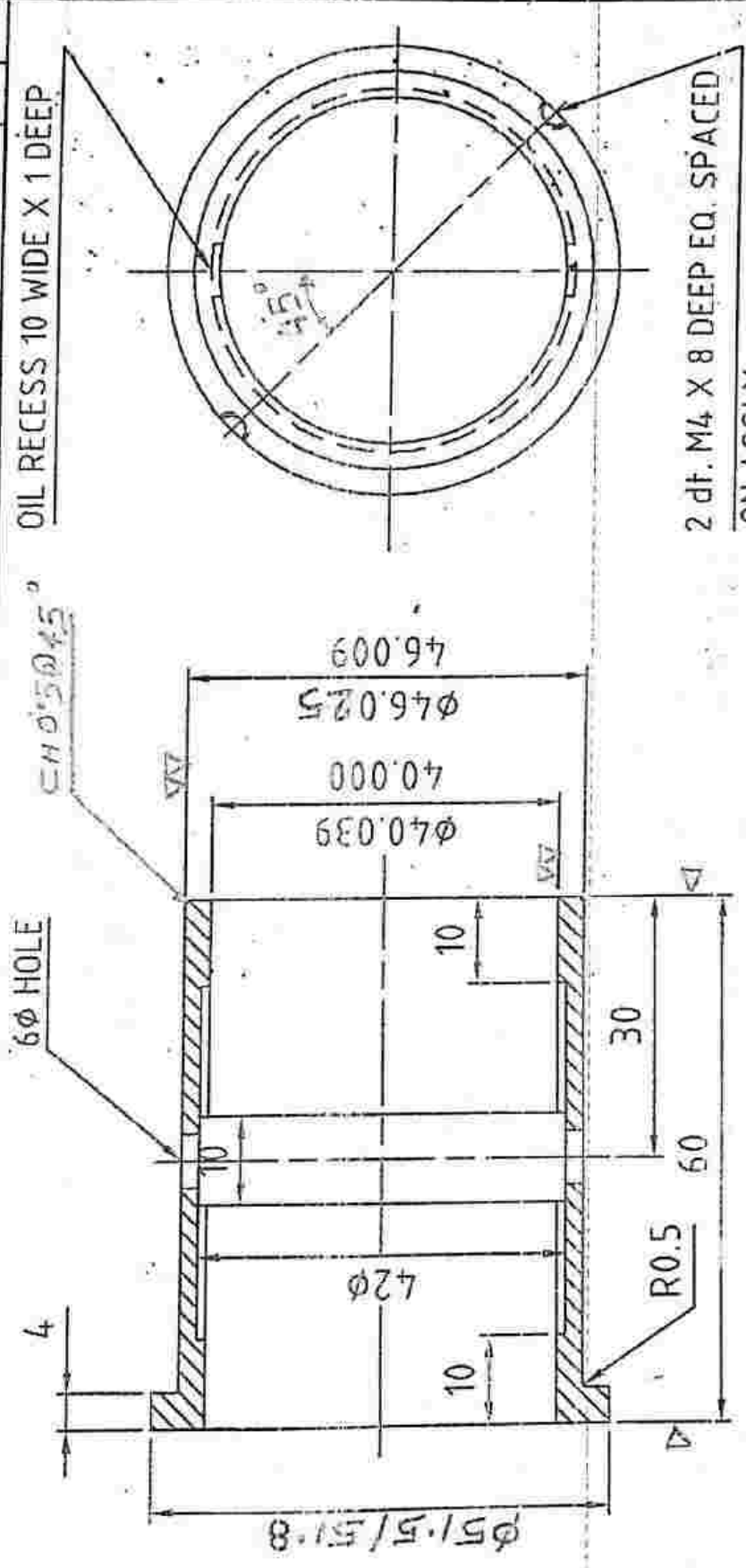

	BUSH		1560.00.346	
	BUREAU-CHIEF	VIKASH KUMAR	SCALE: 1:1	MATERIAL - LG 4C
	CHECKED BY	VIKASH KUMAR		BS:1400
	DESIGNED BY	NAVEEN KUMAR		WEIGHT IN KG. - 0.20
1560.00.300	DRAWN BY	V.S. KUMAR	H.M.B	
REF. Dwg No.				Nov. '19
				HEC LTD., RANCHI
				Rev - 0

UNSPECIFIED TOLERANCES AS PER IS 2102 UNLESS STATED OTHERWISE.

GARDEN REACH SHIPBUILDERS & ENGINEERS LTD., CAL., DECK MACHINERY DIVISION

DRAWN BYR Chakraborty DATE 04.01.07

TRACED BY DATE

CHECKED BY S. GUPTA DATE 16.02.07

APPROVED BY S.K. KAR DATE 16.02.07

EST. WT. ~ 0.86 Kg. SCALE 1:2

MATERIAL LG-4C B.S.-1400

BUSH.

DRAWING NO. 5.07329

YARD NO. 2067-66, 2072-79

REV.	DESCRIPTION	MADE	DATE
A			
B			
C			

∇∇ The Rest

3 M6 TAP EQUI.

SPACED ON ASSY.

WITH CABLE LIFTER

DRG. NO 1560.00.434

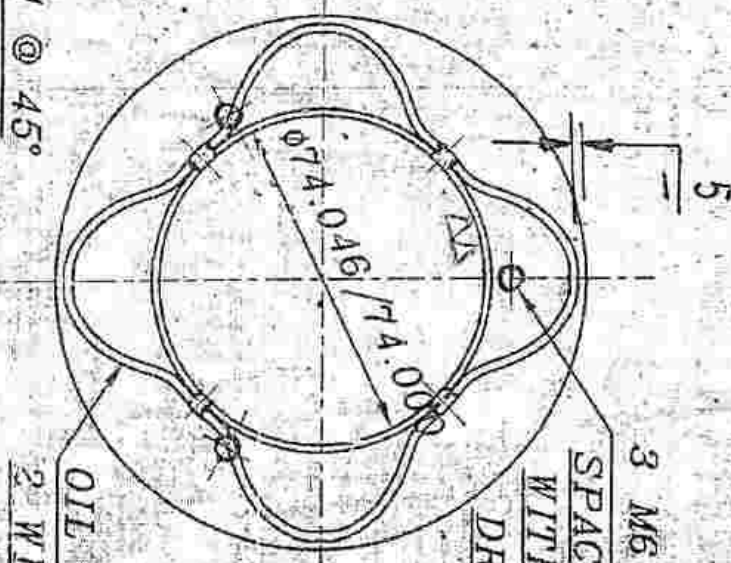
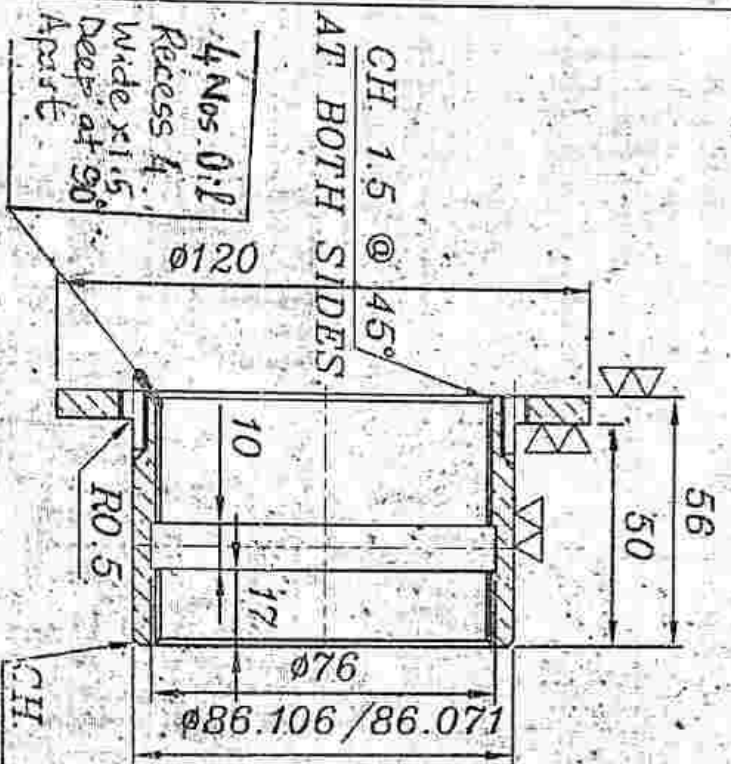

OIL RECESS
2 WIDE X 1 DEEP

BUSH

1560.00.403



BUREAU/CLIENT	VIKASH KUMAR	SCALE-1:2
CHECKED BY	VIKASH KUMAR	WEIGHT IN KG - 0.86
DESIGNED BY	NAVEEN KUMAR	
DRAWN BY	V.S. KUMAR	
REF. DRG. NO.	Vinay B.	

H.M.B

Jan. '20

HEC LTD. RANCHI

Rev.-0

UNSPECIFIED TOLERANCES AS PER IS 2102 UNLESS STATED OTHERWISE.

OS/79/0005 REV. 01

GARDEN REACH SHIPBUILDERS & ENGINEERS LTD, CAL, DECK MACHINERY DIVISION

DRAWN BYR. Chakraborty DATE 05.01.07

TRACED BY DATE

CHECKED BY S. GUPTA DATE 15.02.07

APPROVED BY S.K. KAR DATE 15.02.07

EST. WT. ~0.7 Kg. SCALE 1:2

DRAWING NO. 5.07330

YARD NO. 2057-66, 2072-79

REV.	DESCRIPTION	MADE	DATE
A			
B			
C			

BUSH

MATERIAL EC-4C B.S.-1400

VV The Rest

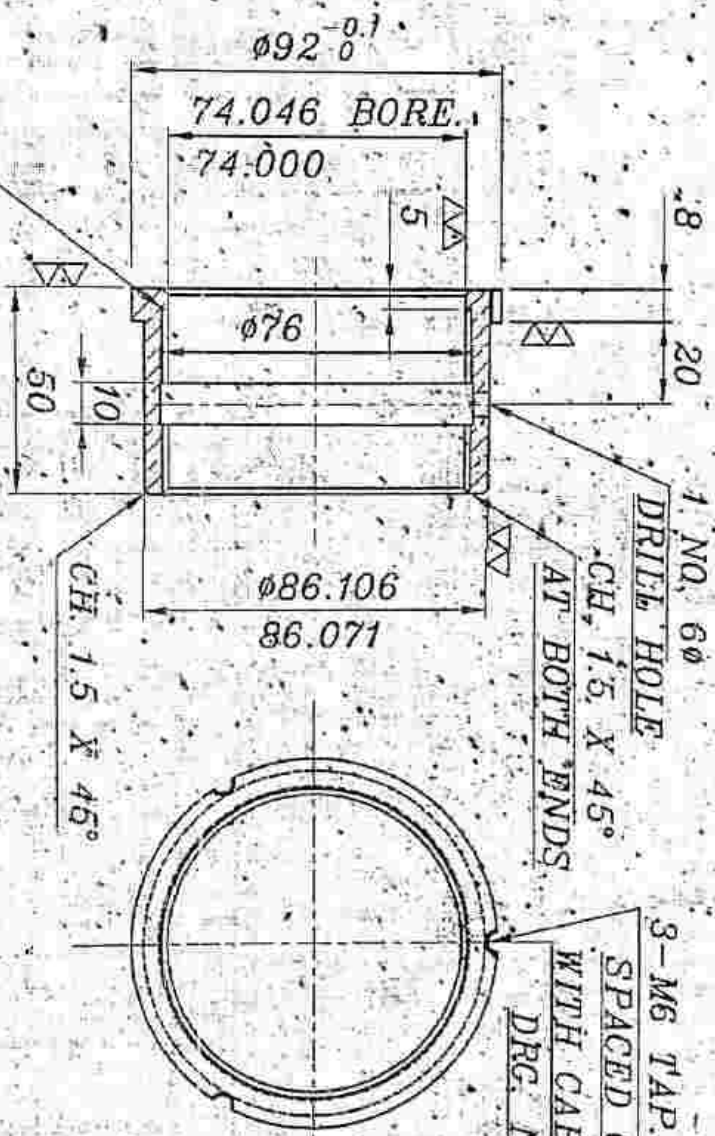

2 NOS. OIL RECESS
8 WIDE X 1.5 DEEP AT 180° APART



BUSH

1560.00.404

DESIGNED BY	VIKASH KUMAR	SCALE-1:2	WEIGHT	1560.00.404
CHECKED BY	VIKASH KUMAR			
DRAWN BY	V.S. KUMAR			
REF. DRG. NO.				

H.M.B

Jan. '20

UNSPECIFIED TOLERANCES AS PER IS 2102 UNLESS STATED OTHERWISE.

05/70/0005 REV: 01

GARDEN REACH SHIPBUILDERS & ENGINEERS LTD., CAL. DECK MACHINERY DIVISION

DRAWN BYR. Chakraborty DATE 05.01.07

TRACED BY DATE

CHECKED BY S. GUPTA DATE 15.02.07

APPROVED BY S.K. KAIR DATE 15.02.07

EST. WT. ~ 1.8 Kgs. SCALE 1:2

MATERIAL LG-4C B.S.-1400

BUSH

DRAWING NO. 5.072332

YARD NO. 2057-66

REV.	DESCRIPTION	MADE	DATE
A			
B			
C			

1/60" THRU' HOLE

CH. 1.5 X 45°

AT BOTH SIDES.

2 dt. M8 X 15 DEEP

TO SUIT ON

BASE PLATE

DRG. NO. 1560.00.480

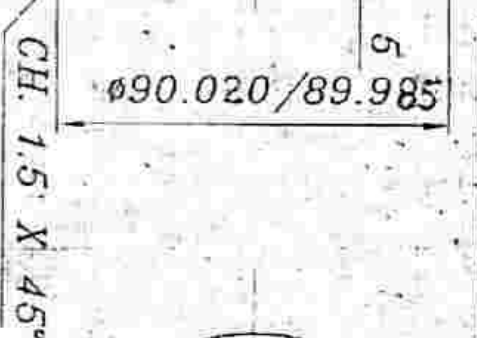
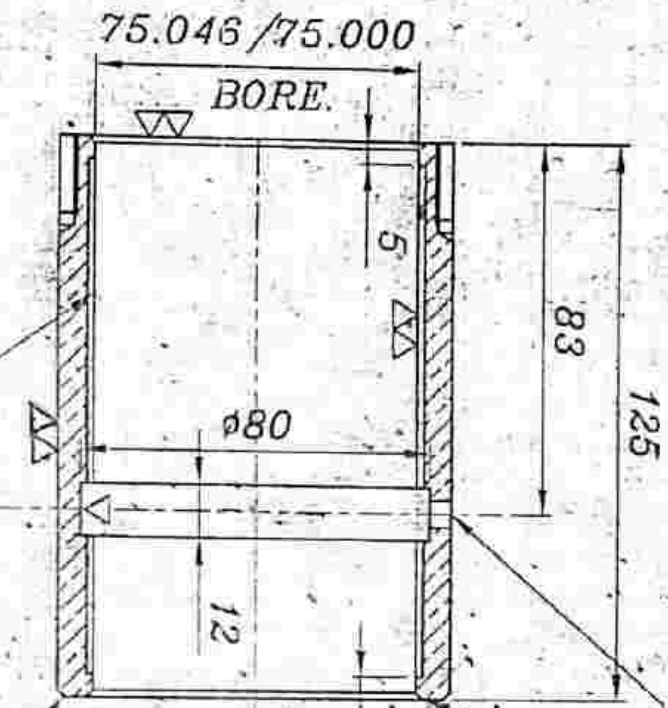

2 ANGLES OIL RECESS
8 WIDE X 1.5 DEEP AT 180° APART.

✓✓ The Rest

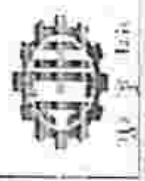

BUSH

1560.00.435

1560.00.480	REF. DRG. NO.
-------------	---------------

DESIGNED BY	VIKASH KUMAR
CHECKED BY	VIKASH KUMAR
APPROVED BY	HAVESH KUMAR
DATE	15/02/07

SCALE	1:2
-------	-----

MATERIAL	LG4C
WEIGHT IN KG.	BS 1400
DATE	Jan. '20
REVISION	Rev.-0

UNSPECIFIED TOLERANCES AS PER IS 2102 UNLESS STATED OTHERWISE.

GARDEN REACH SHIPBUILDERS & ENGINEERS LTD., KOLKATA, DECK MACHINERY DIVISION

DRAWING NO. 4.07227 A

DRAWN BY R. Chakraborty DATE 03.01.17

YARD NO. 2057-66, 2107-12

TRACED BY DATE

**BUSH
(UPPER)**

REV.	DESCRIPTION	MADE	DATE
A	DIM MARKED & CHANGED	S.S.K.	03.10.17
B	FROM M10 TO M6 &		
C	6 NO. TO 3 NO.		

CHECKED BY S. GUPTA DATE 15.01.07

APPROVED BY S.K. KAR DATE 15.02.07

EST. WT. AS STATED SCALE 1:2

MATERIAL LG-4C B.S. 1400

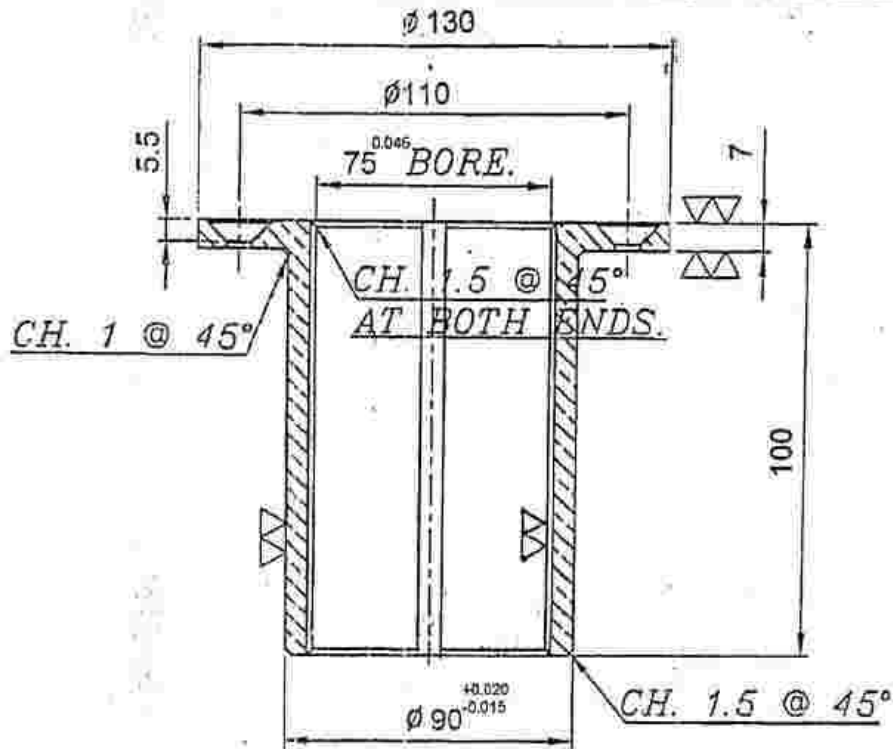

4 NO. - M6 CSK.
HOLES EQ. SPACED
ON '110' P.C.D.

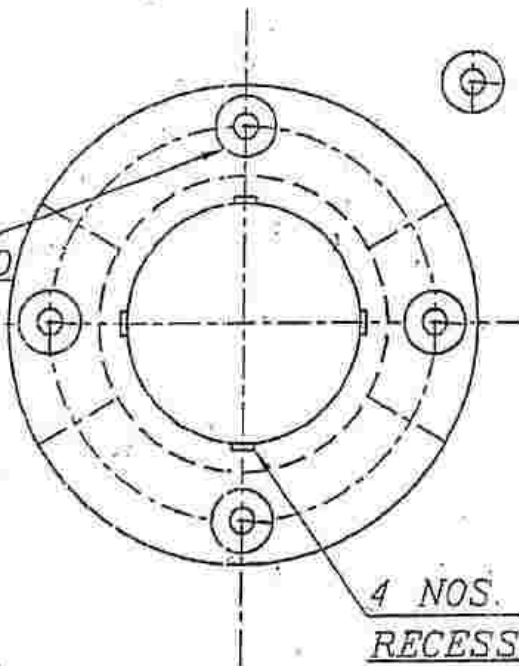

4 NOS. 6 WIDE X 1.5 DEEP
RECESS.

MACHINING-(▽▽)▽

	BUSH (UPPER)		1560.00.458	
			MATERIAL - LG4C BS-1400	
BUREAU CHIEF		VIKASH KUMAR	SCALE-1:2	WEIGHT IN KG - 2.50
CHECKED BY		VIKASH KUMAR	H.M.B Jan. '20 Rev.-0	
DESIGNED BY		NAVEEN KUMAR		
DRAWN BY		S. KUMAR	HEC LTD., RANCHI	
1560.00.400 REF DRG NO.				

QS/70/0004 REV. 01

UNSPECIFIED TOLERANCES AS PER IS 2102 UNLESS STATED OTHERWISE. A 4

GARDEN REACH SHIPBUILDERS & ENGINEERS LTD., KOLKATA, DECK MACHINERY DIVISION		DRAWING NO. 4.07227 A	
DRAWN BY R. Chakraborty	DATE 03.01.17	YARD NO. 2057-66#2109-12	
TRACED BY	DATE	REV.	DESCRIPTION
CHECKED BY S. GUPTA	DATE 15.01.07	A	DIM MARKED A) CHANGED
APPROVED BY S.K. KAL	DATE 15.02.07	B	FROM M10 TO M8 &
EST. WT. AS STATED	SCALE 1:2	C	6 NO. TO 3 NO.
MATERIAL LG-4C B.S. 1400		MADE	DATE

**BUSH
(LOWER)**

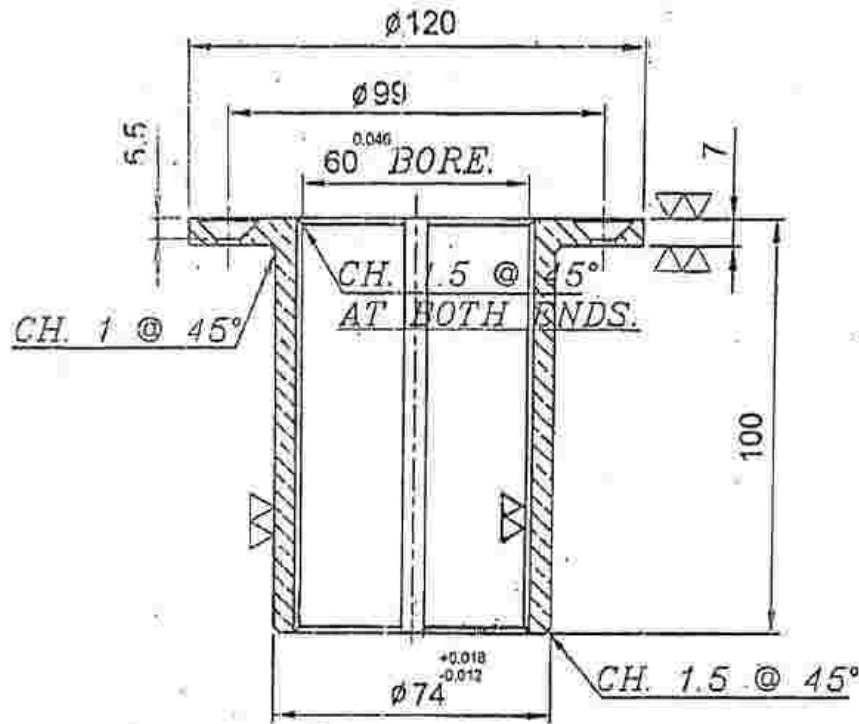

8 NO. - M6 CSK.
HOLES EQ. SPACED
ON '99' F.C.D.

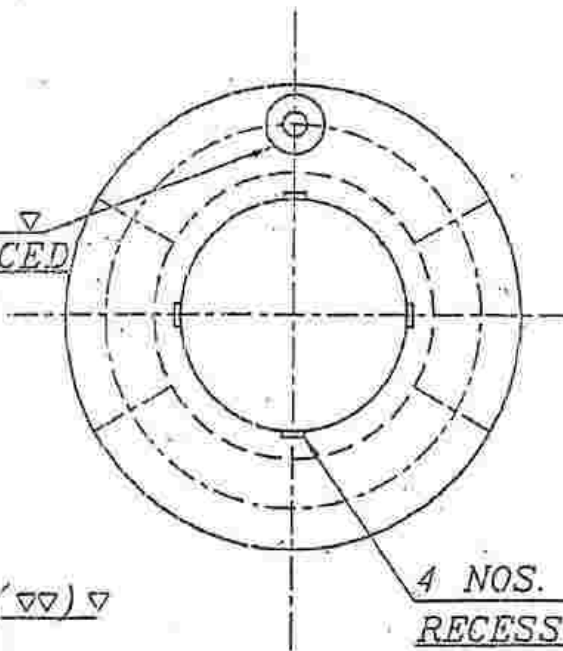

MACHINING - (▽▽) ▽

4 NOS. 6 WIDE X 1.5 DEEP
RECESS.

	BUSH (LOWER)		1560.00.497	
			MATERIAL - LG4C BS:1400	
1560.00.400 REF DRG NO.	DESIGNED BY V.S. KUMAR	DRAWN BY V.S. KUMAR	SCALE - 1:2	WEIGHT IN KG. - 1.40
			H.M.B HEC LTD. RANCHI	
				Jan. '20 Rev.-0

QS/70/0004 REV. 01 UNSPECIFIED TOLERANCES AS PER IS 2102 UNLESS STATED OTHERWISE. A 4

GARDEN REACH SHIPBUILDERS & ENGINEERS LTD. CAL.-DECK MACHINERY.

SK No. 5-16017

YARD No. 2107-111.

DESCRIPTION
BUSH

MATERIAL: LG-4, B.S.1400

DATE 2.11.91

DATE 28.2.92

SCALE 1:1

REV.	DESCRIPTION	DATE
A		
B		

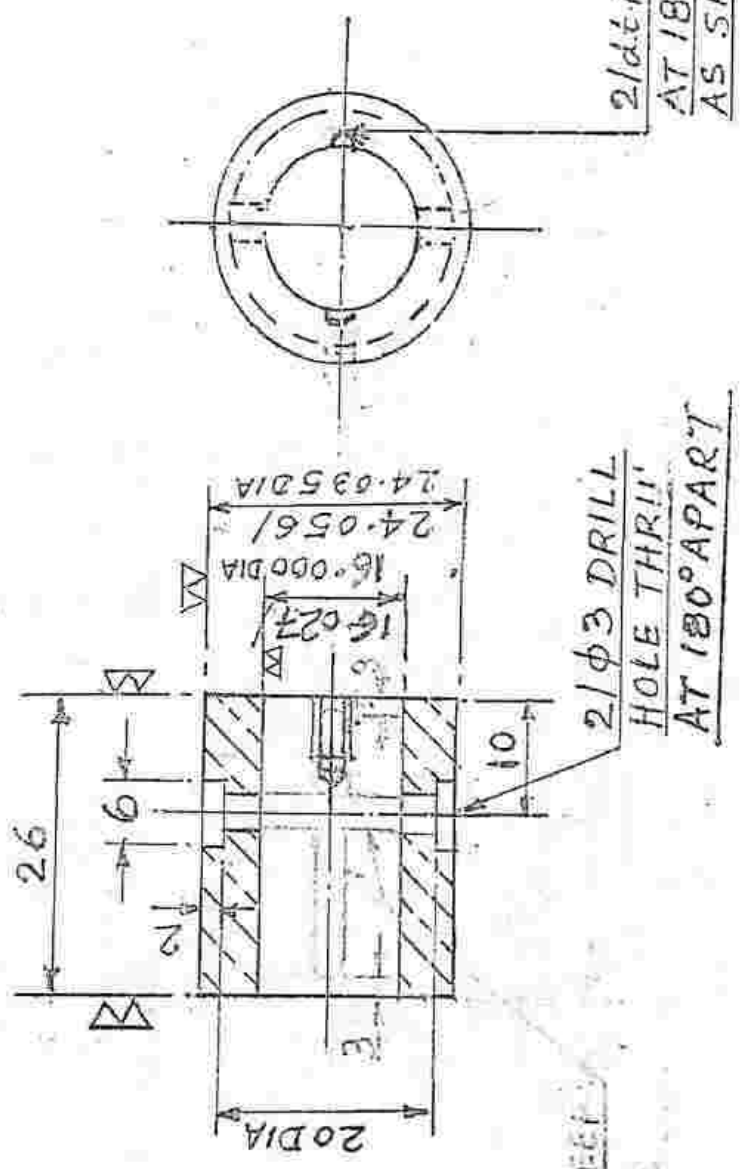

3 WIDE X 1 DEEP
ON GROOVE

	BUSH		1560.00.507
	DURCAU-DIRECT	VIKASH KUMAR	SCALE-1:1
CHECKED BY	VIKASH KUMAR		
DESIGNED BY	HAIVEN KUMAR		
DRAWN BY	V.S. ILLIAR		
1560.00.550			
REF DRG NO			
		H.M.B	Jan. '20
		HECLTD., RANCHI	Rev.-0
		MATERIAL BS:1100	
		WEIGHT IN KG - 0.056	

DRAWING NO. 5.07337
 YARD NO. 2057-66.
 REV. DESCRIPTION MADE DATE
 A
 B
 C

BUSH.
 MATERIAL LC-1C BS-1400

DRAWN BYR. Chakraborty DATE 11.01.07
 TRACED BY DATE
 CHECKED BY S. GUPTA DATE 15.02.07
 APPROVED BY S.K. KAR. DATE 15.02.07
 EST. WT. 1.95 Kgs. SCALE 1:1

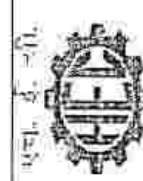
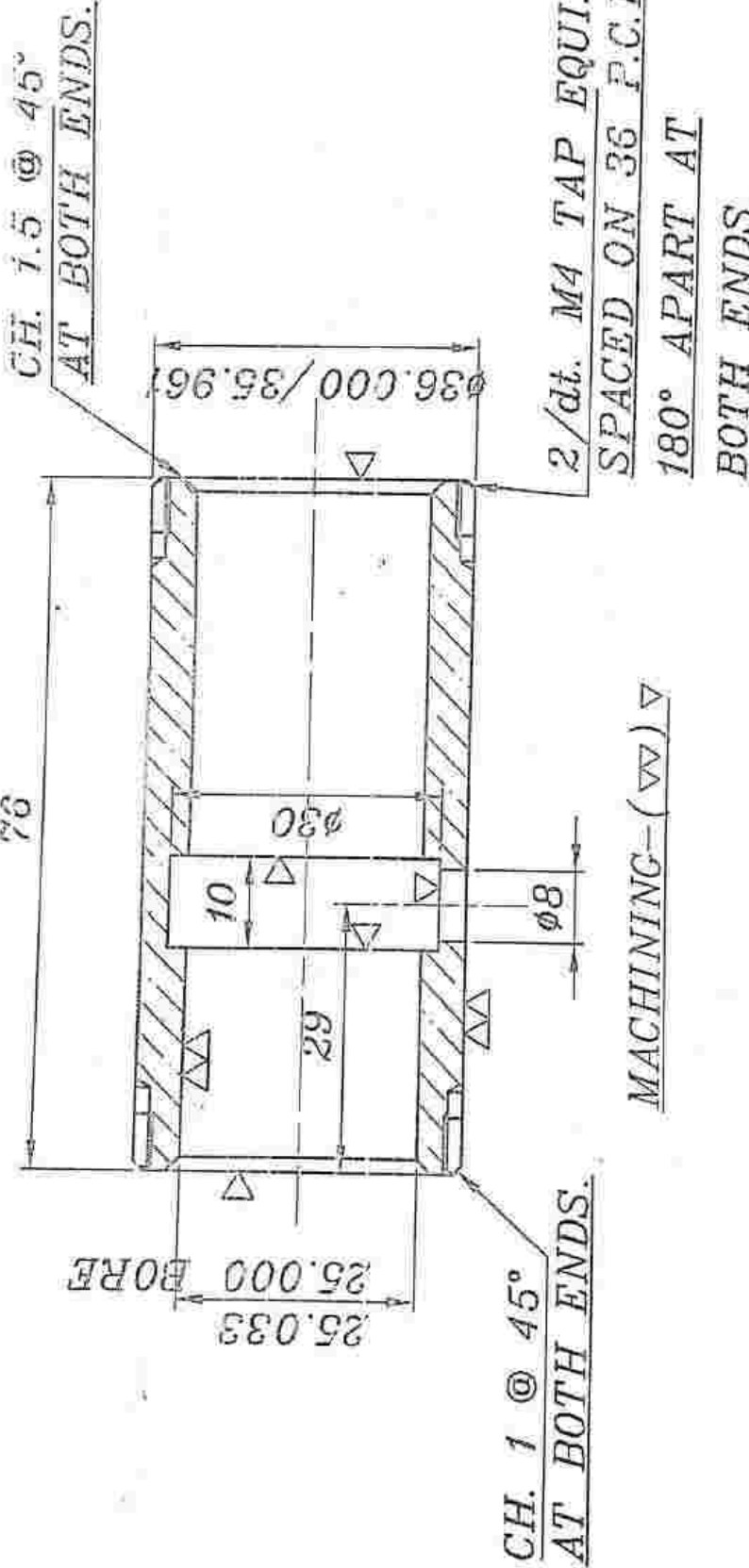

1560.00.400	DESIGNED BY	VIKASH KUMAR	SCALE 1:1	MATERIAL - BS.1400	1560.00.512
REF. DRE. NO.	DRAWN BY	V.S. KUMAR		WORKED DRAWN - 1.95	
	CHECKED BY	VIKASH KUMAR			
	DESIGNED BY	VIKASH KUMAR			
	DRAWN BY	V.S. KUMAR			

H.M.B
 HEG LTD., RANCHI
 Jan. '20
 Rev.-0

UNSPECIFIED TOLERANCES AS PER IS 2102 UNLESS STATED OTHERWISE.

GARDEN REACH SHIPBUILDERS & ENGINEERS LTD. CAL-DECK MACHINERY.

SK No. 5-16018

DRAWN *S.K.M.* DATE 4.11.91

YARD No. 2107-12

TRACED DATE DATE 28.2.92

REV.	DESCRIPTION	DATE
A		
B		

BUSH

MATERIAL: LG 45 BS 1400

EST. WT. 0.09 kg. SCALE 1:1

∇ (W)

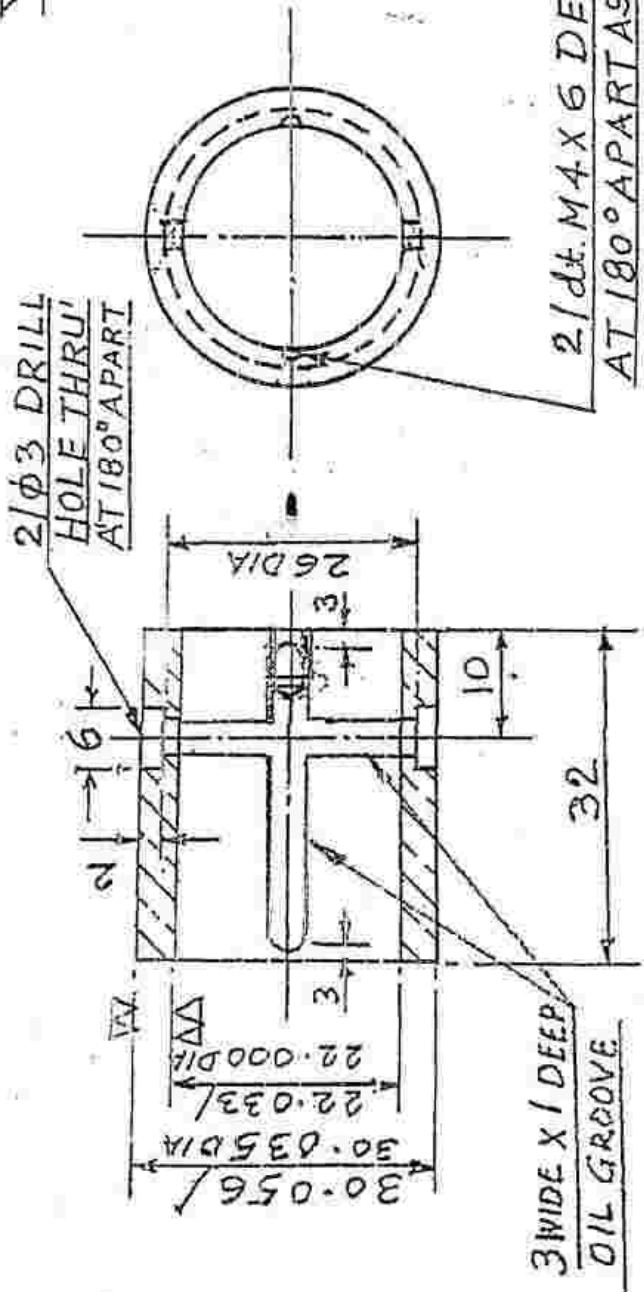

2/dt. M4 X 6 DEEP AT 180° APART AS SHOWN.



BUSH

1560.00.529

MATERIAL- LG4C
BS:1400
WEIGHT IN KG.- 0.09

DURCAU-CHIEF	VIKASH KUMAR
CHECKED BY	VIKASH KUMAR
DESIGNED BY	NAVEEN KUMAR
DRAWN BY	V.S. KUMAR

Jan. '20

H.M.B



Rev.-0

HEC LTD., RANCHI

1560.00.550
REF DRG NO

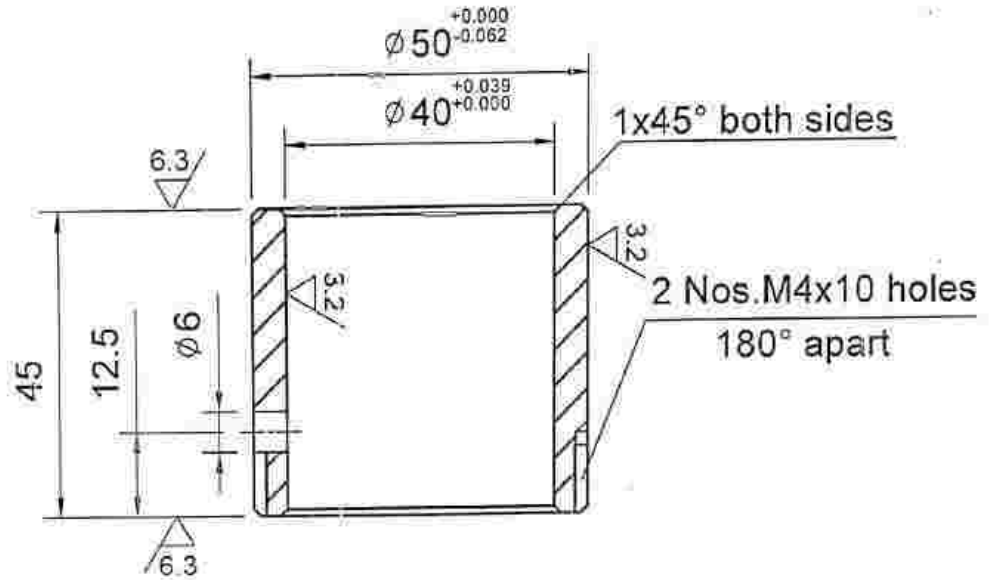

1560.00.534

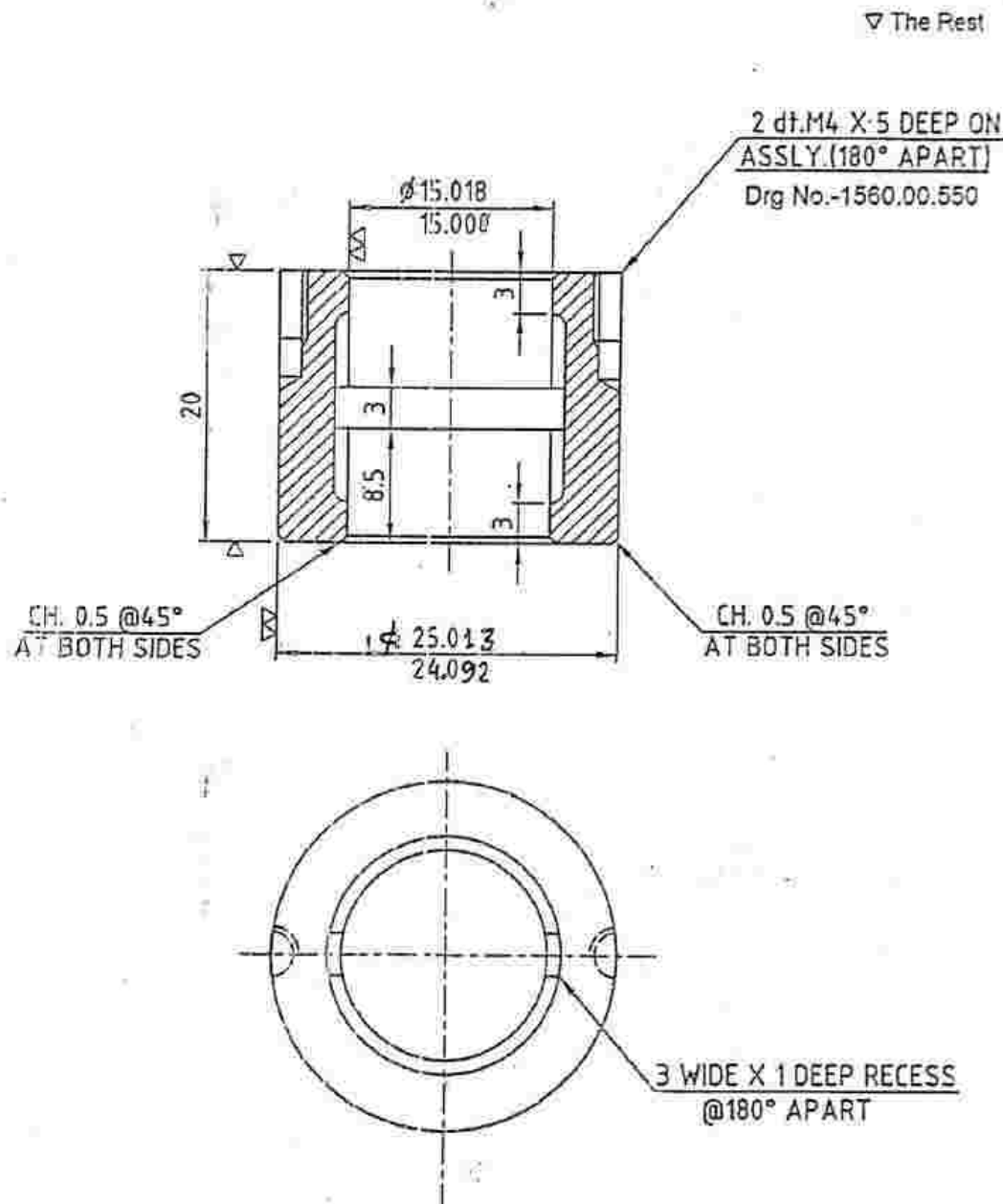

	<h1>BUSH</h1>			1560.00.534		
				MATERIAL- LG 4C BS 1400		
	BUREAU-CHIEF	VIKASH KUMAR		SCALE-1:1	WEIGHT IN KG.- 0.25	
	CHECKED BY	VIKASH KUMAR		H.M.B. HEC LTD.,RANCHI	Feb. '20	
	DESIGNED BY	NAVEEN KUMAR	Rev.-0			
1560.00.530	DRAWN BY	V.S.KUMAR				
REF.DWG NO.						

GARDEN REACH SHIPBUILDERS & ENGINEERS LTD., KOLKATA, DECK MACHINERY DIVISION		DRAWING NO. 4.07236																	
DRAWN BY S.GAYEN	DATE 20.09.07	YARD NO. 2057-66, 2057-32																	
TRACED BY	DATE	<table border="1"> <thead> <tr> <th>REV.</th> <th>DESCRIPTION</th> <th>MADE</th> <th>DATE</th> </tr> </thead> <tbody> <tr> <td>A</td> <td></td> <td></td> <td></td> </tr> <tr> <td>B</td> <td></td> <td></td> <td></td> </tr> <tr> <td>C</td> <td></td> <td></td> <td></td> </tr> </tbody> </table>		REV.	DESCRIPTION	MADE	DATE	A				B				C			
REV.	DESCRIPTION			MADE	DATE														
A																			
B																			
C																			
CHECKED BY S. GAYEN	DATE 20.09.07	<p style="text-align: center;">BUSH</p>																	
APPROVED BY	DATE																		
EST. WT.	SCALE 2:1	MATERIAL LG 4C BS 1400																	



	BUSH		1560.00.554	
			MATERIAL LG4C BS 1400	
BUREAU-CHIEF	VIKASH KUMAR		SCALE: 2:1	WEIGHT IN KG - 0.05
CHECKED BY	VIKASH KUMAR			H.M.B HEC LTD. RANCHI
DESIGNED BY	NAVJIT KUMAR	Jan. '20		
1560.00.55C	DRAWN BY	V.S. KUMAR	Rev.-0	
REF. DRG. 13				

QS/70/0004 REV. 01 UNSPECIFIED TOLERANCES AS PER IS 2102 UNLESS STATED OTHERWISE. A 4

GARDEN REACH SHIPBUILDERS & ENGINEERS LTD., KOLKATA, DECK MACHINERY DIVISION		DRAWING NO. 4.07238	
DRAWN BY S.GAYEN	DATE 20.03.07	YARD NO. 2057-66, 2/09-12	
TRACED BY	DATE	REV.	DESCRIPTION
CHECKED BY	DATE	A	
APPROVED BY	DATE	B	
EST.WT.	SCALE 1:1	C	
MATERIAL LG-4C-BS 1400		BUSH	

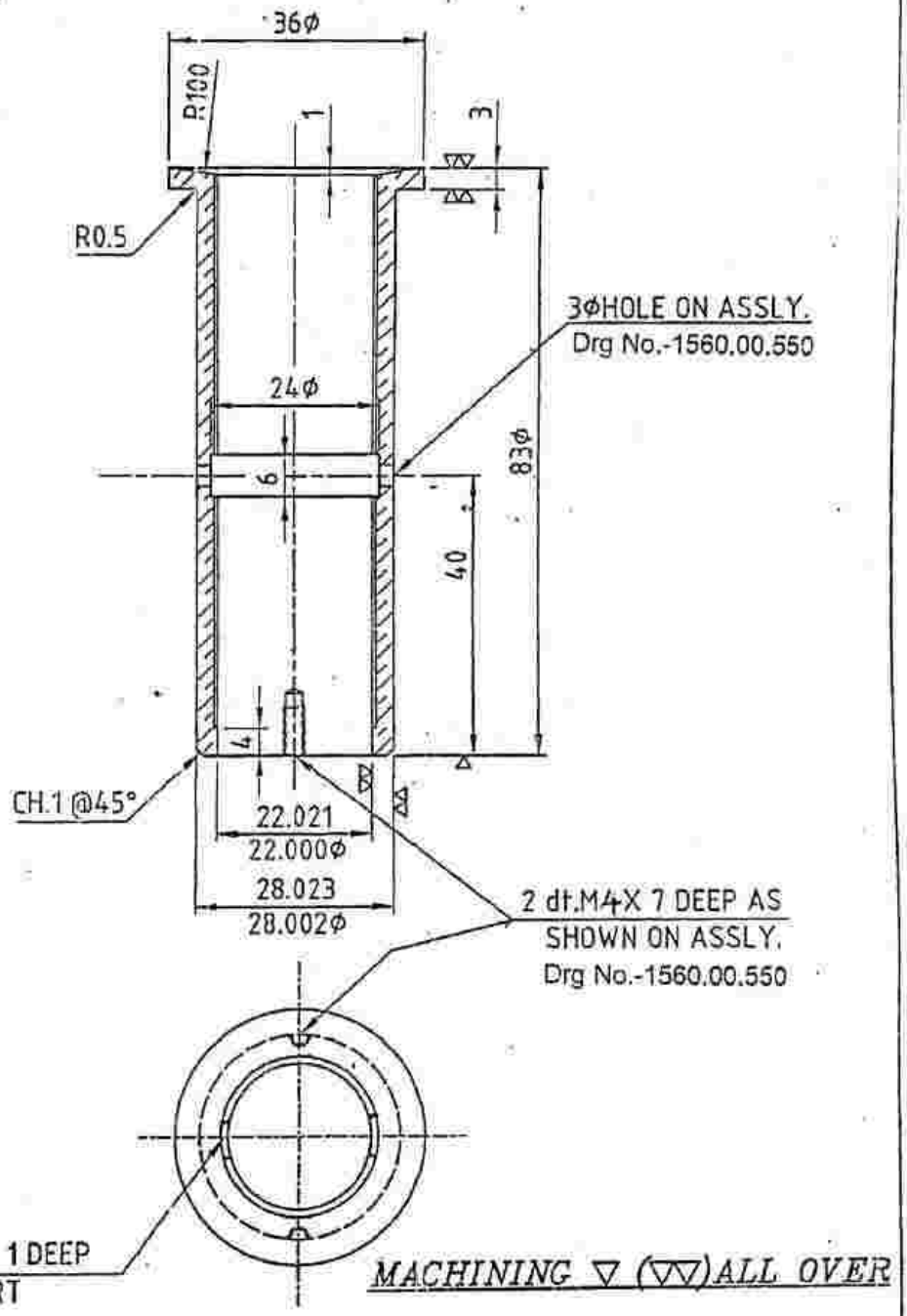

	BUSH		1560.00.558	
			MATERIAL- LG4C BS:1400	
	BUREAU CHIEF	VIKASH KUMAR	SCALE-1:1	WEIGHT IN KG- 0.22
	CHECKED BY	VIKASH KUMAR	H.M.B	Jan. '20
	DESIGNED BY	KAIVEN KUMAR		
1560.00.550	DRAWN BY	J.S. KUMAR	HEC LTD., RANCHI	
REF DRG. NO.			Rev.-0	

OS/70/0004 REV. 01 UNSPECIFIED TOLERANCES AS PER IS 2102 UNLESS STATED OTHERWISE. A 4

GARDEN REACH SHIPBUILDERS & ENGINEERS LTD. CAL. DECK MACHINERY.

SK NO. 5-16017

DESCRIPTION

BUSH

MATERIAL: I.G-45, B.S. 1400

DRAWN: *Sobha* DATE 2.11.91

TRACED: DATE

CHECKED: *Mans* DATE 28.2.92

EST. WT. 0.030 kg SCALE 1:1

REV. A DESCRIPTION DATE

B

VV

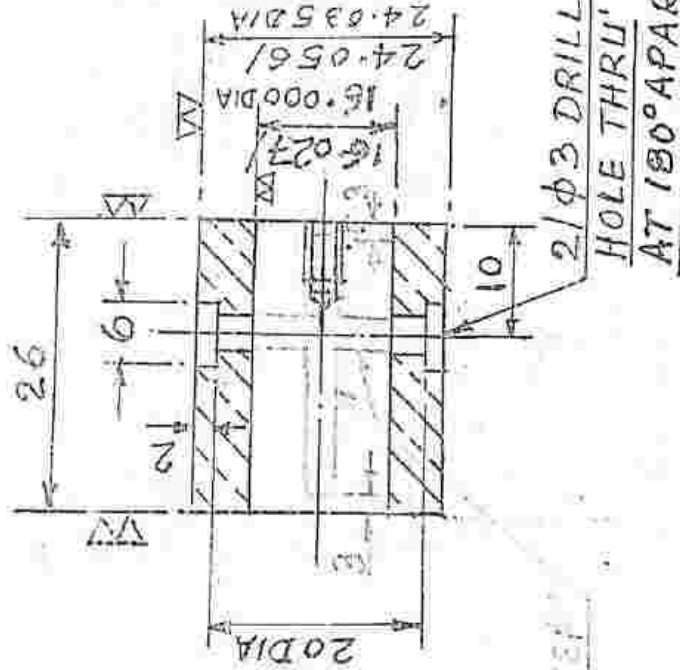

32705 VICE
D.P. SPOON

1560.00.550
REF DRG. NO.

BUREAU-CHIEF	VIKASH KUMAR	SCALE-1:1	1560.00.564
CHECKED BY	VIKASH KUMAR	MATERIAL-	LGIC
DESIGNED BY	NAVEEN KUMAR	WEIGHT IN KG-	BS-1400
DRAWN BY	V.S. KUMAR	HEG LTD., RANCHI	0.036

1560.00.564	Jan. '20
H.M.B	Rev.-0

GARDEN REACH SHIPBUILDERS & ENGINEERS LTD. CAL. DECK MACHINERY.

SK No. 5-16018

DRAWN *S.K.M.S* DATE 4.11.91

YARD No. 2109-12

TRAGED DATE

REV. A DESCRIPTION DATE

CHECKED *M.S.A.* DATE 28.2.92

REV. B

EST. WT. 0.09 kg. SCALE 1:1

MATERIAL LG 42 BS 1400

DESCRIPTION

BUSH

∇ (W)

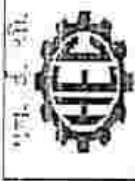
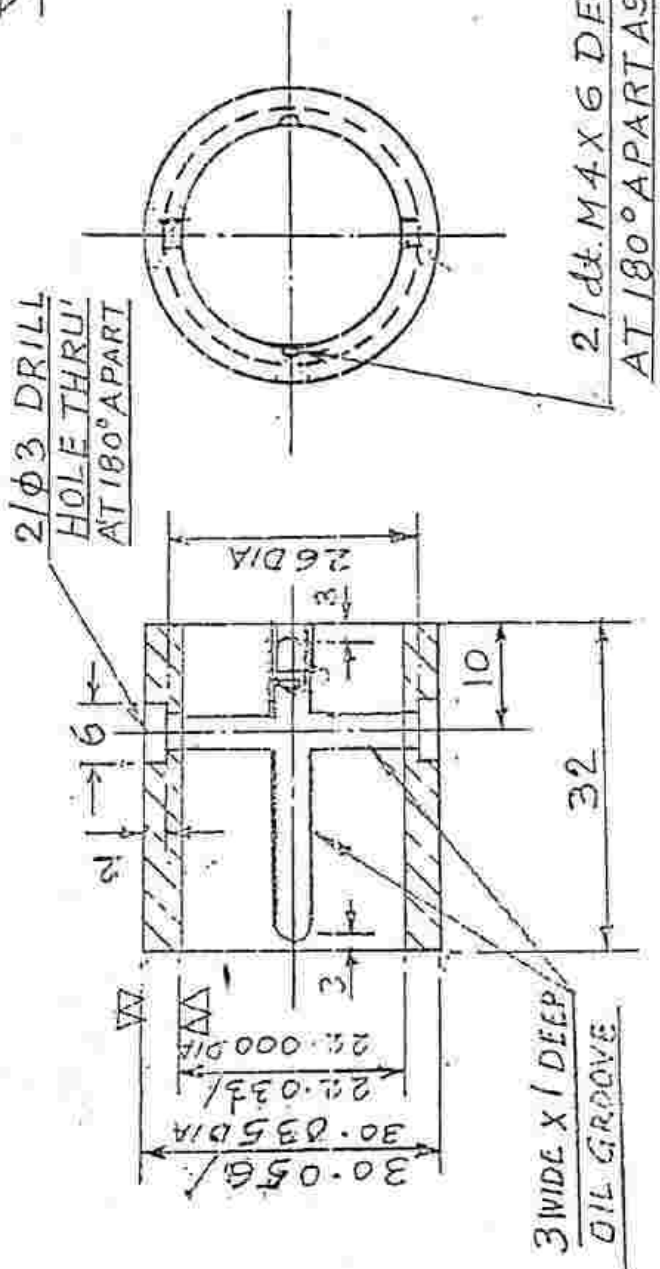

BUSH

1560.00.567

DURCAL-CHIEF	VIKASH KUMAR	SCALE-1:1	MATERIAL - LG 42 BS 1400
CHECKED BY	VIKASH KUMAR	WEIGHT IN KG - 0.09	
DESIGNED BY	HARESH KUMAR		
DRAWN BY	V.S. KUMAR		
1560.00.567	H.M.B	Jan. '20	Rev.-0
REF. DRG. NO.	HEC LTD. RANCHI		

GARDEN REACH SHIPBUILDERS & ENGINEERS LTD. CAL. DECK MACHINERY.

SK NO. 5-16019A

DRAWN *[Signature]* DATE 5.11.91

TRACED DATE

CHECKED *[Signature]* DATE 28.2.92

EST. WT. 0.054 kg SCALE 1:1

DESCRIPTION

BUSH

MATERIAL: LG-4 BS-1400

REV. A B

DESCRIPTION

DATE

V (VV)

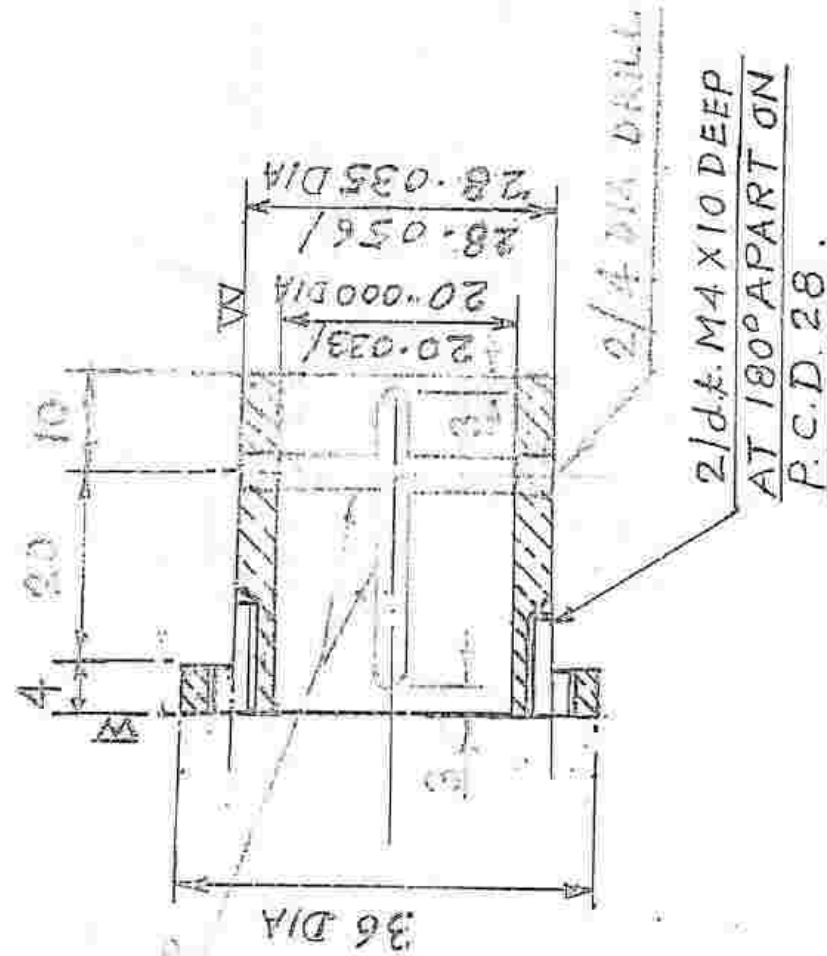

36 DIA
2/dk. M4 X 10 DEEP
AT 180° APART ON
P.C.D. 28.

VEL. & S.H.



BUREAU-CHIEF	VIKASH KUMAR
CHECKED BY	VIKASH KUMAR
DESIGNED BY	NAVEEN KUMAR
DRAWN BY	V.S. KUMAR

1560.00.550
REF Dwg NO

BUSH

1560.00.569

MATERIAL- LG4C
BS.1400

SCALE-1:1

H.M.B

Jan. '20

HEC LTD. RANCHI

Rev. 0

GARDEN REACH SHIPBUILDERS & ENGINEERS LTD., CAL., DECK MACHINERY DIVISION

DRAWING NO. 5.07355

DRAWN BY S.GAYEN DATE 20.03.07

TRACED BY DATE

CHECKED BY DATE

APPROVED BY DATE

EST. WI.

SCALE 2:1 MATERIAL IC 4C BS 1400

BUSH

REV.	DESCRIPTION	MADE	DATE
A			
B			
C			

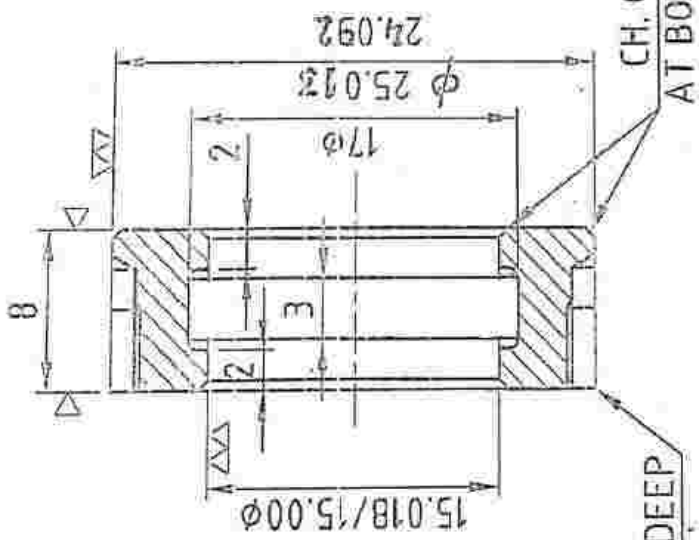

2 dt. M4 X 5 DEEP ON ASSY.

3 WIDE X 1 DEEP RECESS @180° APART

▽ The Rest

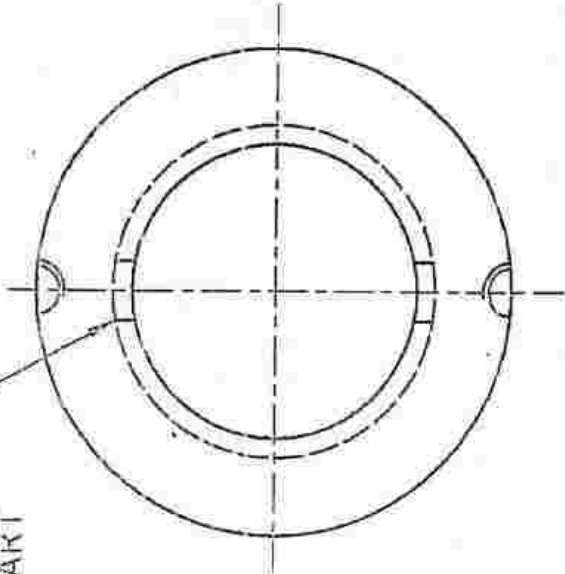

HEC LTD. RANCHI

1560.00.550
REF DRP NO

BUSH

1560.00.571

MATERIAL: LG4C BS:1400
WEIGHT IN KG - 0.15

SCALE: 2:1

DUREAU CHIEF: VIKASH KUMAR
OFFICER IN CH: VIKASH KUMAR
DESIGNED BY: HAVEN KUMAR
DRAWN BY: V.S. KUMAR

Jan. '20

H.M.B

HEC LTD., RANCHI

Rev.-0

UNSPECIFIED TOLERANCES AS PER IS 2102 UNLESS STATED OTHERWISE.

CS/70/0005 REV. 01

AR

GARDEN REACH SHIPBUILDERS & ENGINEERS LTD., KOLKATA, DECK MACHINERY DIVISION

DRAWING NO. 4.07239

DRAWN BY S. GAYEN DATE 12.06

YARD NO. 2057-66; 2109-12

TRACED BY DATE

TRUNION NUT

CHECKED BY DATE

REV.	DESCRIPTION	MADE	DATE
A			
B			
C			

APPROVED BY DATE

EST. WT. SCALE 1:1

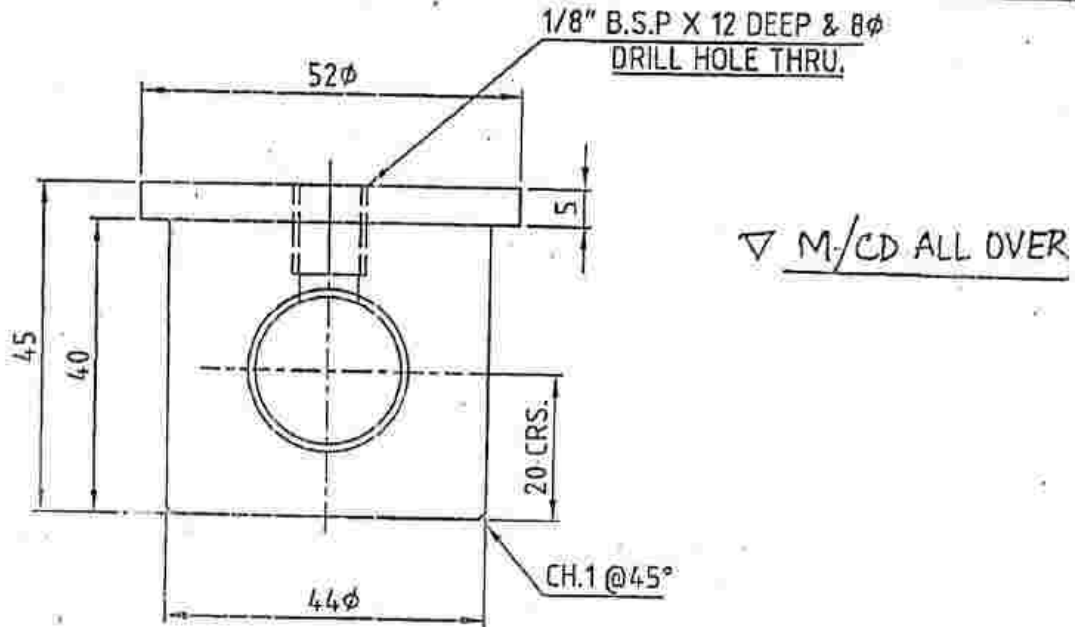

MATERIAL G1C, B.S 1400

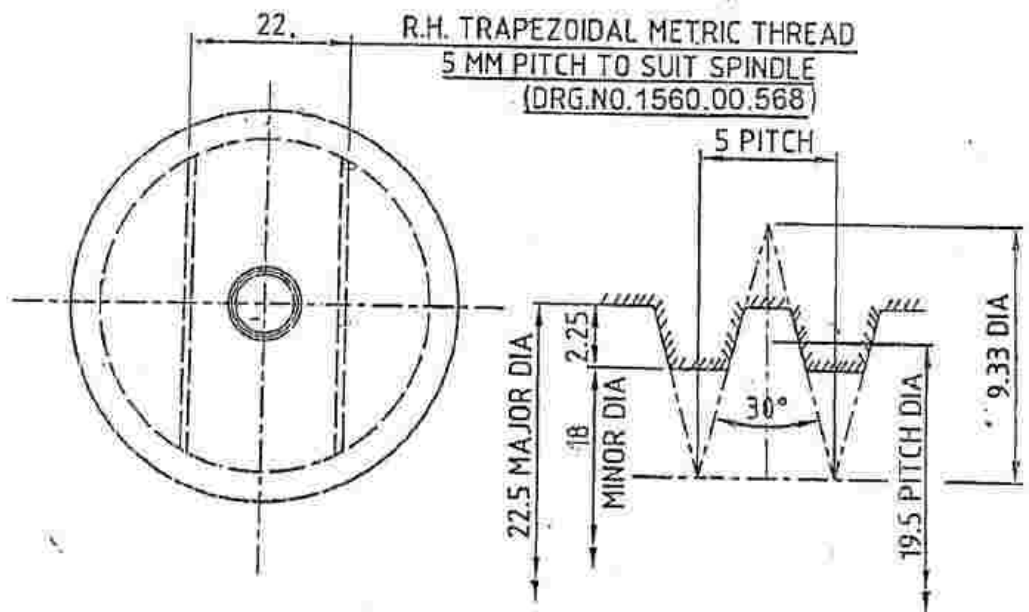

▽ M/CD ALL OVER



DETAIL OF TRAPEZOIDAL THREAD

	TRUNION NUT		1560.00.576	
			MATERIAL- G1C BS:1400	
BUREAU CHIEF	VIKAS KUMAR		SCALE-1:1	WEIGHT IN KG - 0.50
CHECKED BY	VIKAS KUMAR		H.M.B HEC LTD, RANCHI	Jan. '20
DESIGNED BY	NAVEEN KUMAR			Rev.-0
1560.00.550 REF DRG. NO	DRAWN BY	V.S. KUMAR		

QS/70/0004 REV. 01 UNSPECIFIED TOLERANCES AS PER IS 2102 UNLESS STATED OTHERWISE. A 4

GARDEN REACH SHIPBUILDERS & ENGINEERS LTD. CAL.-DECK MACHINERY.

DRAWN S.K.C. DATE 24.12.99
 TRACED _____ DATE _____
 CHECKED M.M. DATE 24.12.99
 EST. WT. 025 Kg SCALE 2:1

DESCRIPTION

SPECER

MATERIAL: LG-A, BS 1400

SK No. 5-16031

YARD No. 2109-12

REV.	DESCRIPTION	DATE
A		
B		

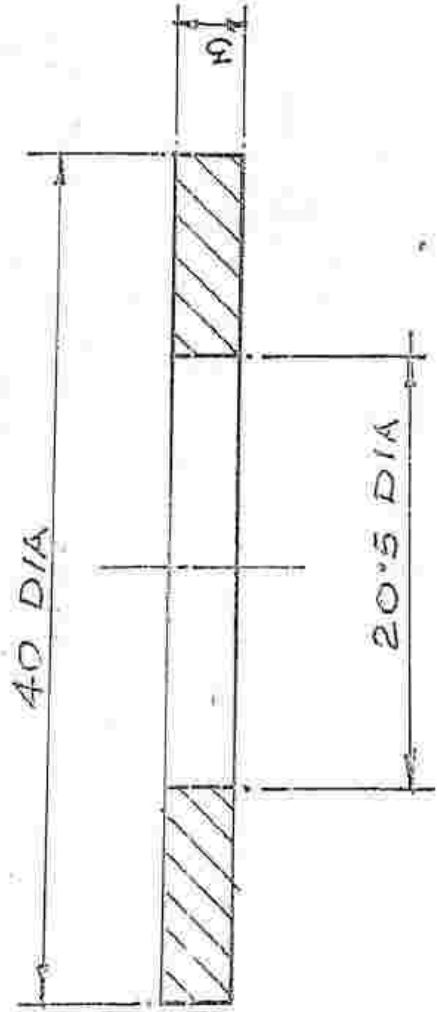

∇∇ All Over

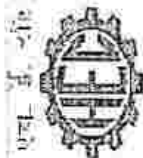

SPACER

1560.00.578

DESIGNED BY	VIKASH KUMAR	SCALE-2:1	LGH
CHECKED BY	VIKASH KUMAR		MATERIAL - BS 1400
DESIGNED BY	NAVEEN KUMAR		WEIGHT IN KG - 0.025
DRAWN BY	V.S. KUMAR		
1560.00.550			
REF DRG NO			
	H.M.B		Jan '20
	HEELD, RANGHI		Rev - 0

GARDEN REACH SHIPBUILDERS & ENGINEERS LTD. CALCUTTA.

DECK MACHINERY DIVISION

DRAWN *[Signature]* DATE 24.1.89

DESCRIPTION

SK No. 4*07092

TRACED DATE

BUSH

REV. | | | | |

CHECKED *[Signature]* DATE 3.7.89

MATERIAL - GIC BS1400

SCALE - 1:2.5

EST. WT - 14 KGS.

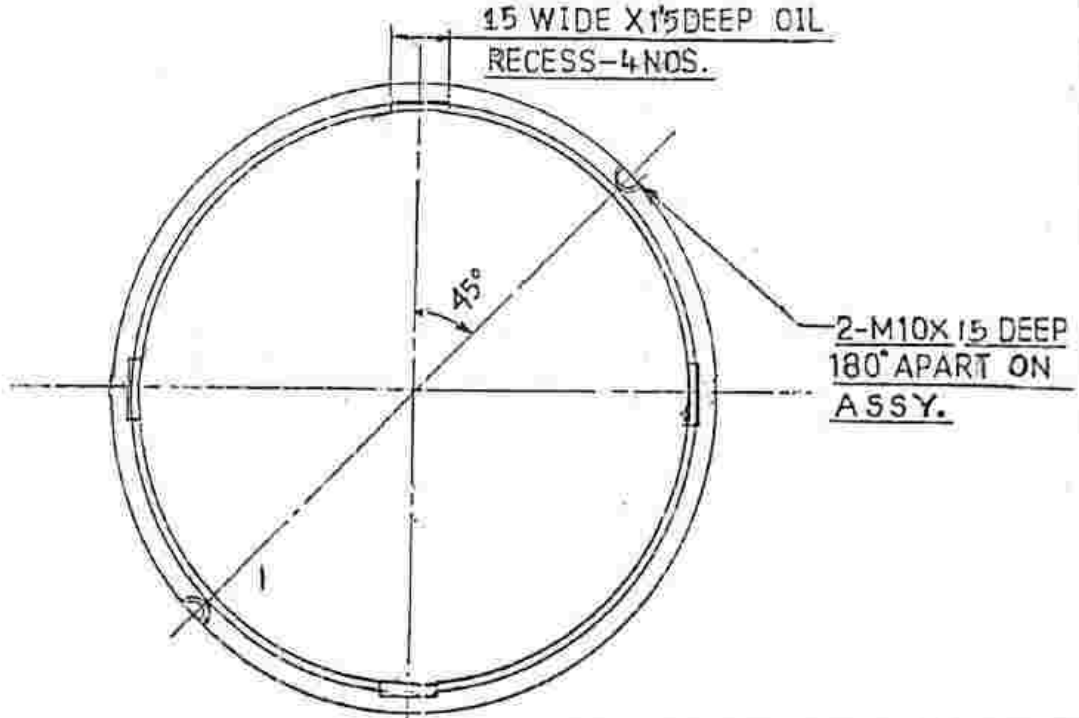
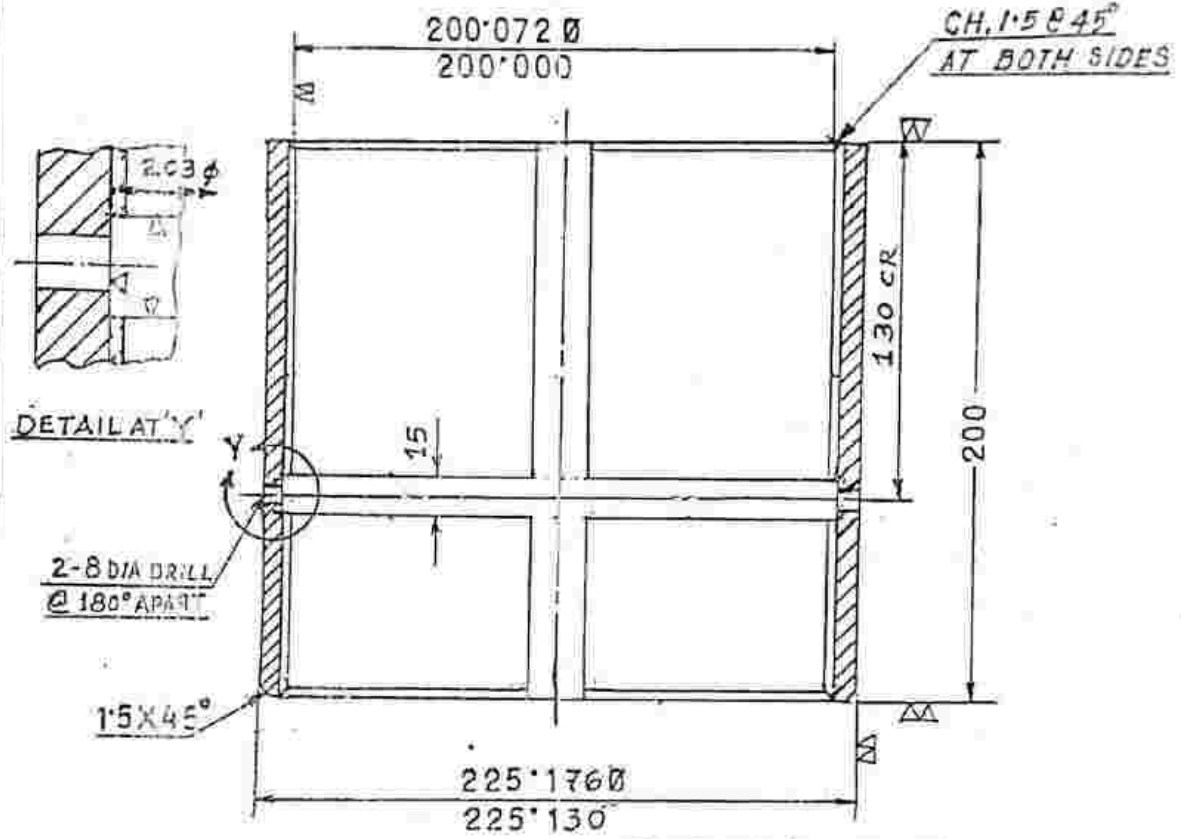

	BUSH			1560.00.601	
				GIC MATERIAL - BS:1400	
	BUREAU-CHIEF	VIKASH KUMAR	<i>[Signature]</i>	SCALE: 1:2.5	WEIGHT IN KG. - 14.00
	CHECKED BY	VIKASH KUMAR			
	DESIGNED BY	NAVEEN KUMAR	<i>[Signature]</i>	H.M.B	
1560.00.400	DRAWN BY	V.S. KUMAR		HEC LTD. RANCHI	
REF DPG NO					Rev.-0

DRAWN *Amrinder* DATE 24.1.89

DESCRIPTION

SK No. 4.07093

TRACED DATE

BUSH FOR CABLE LIFTER

SK No. 4.07093

CHECKED *(Signature)* DATE 3.7.89

REV.

EST. WT- 10 KGS

MATERIAL- G.I.C BS 1400

SCALE- 1:2.5

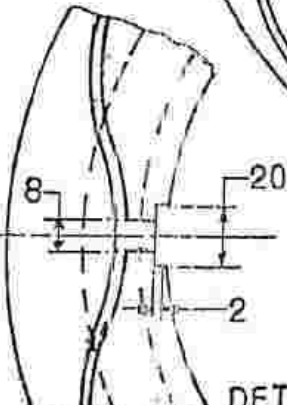
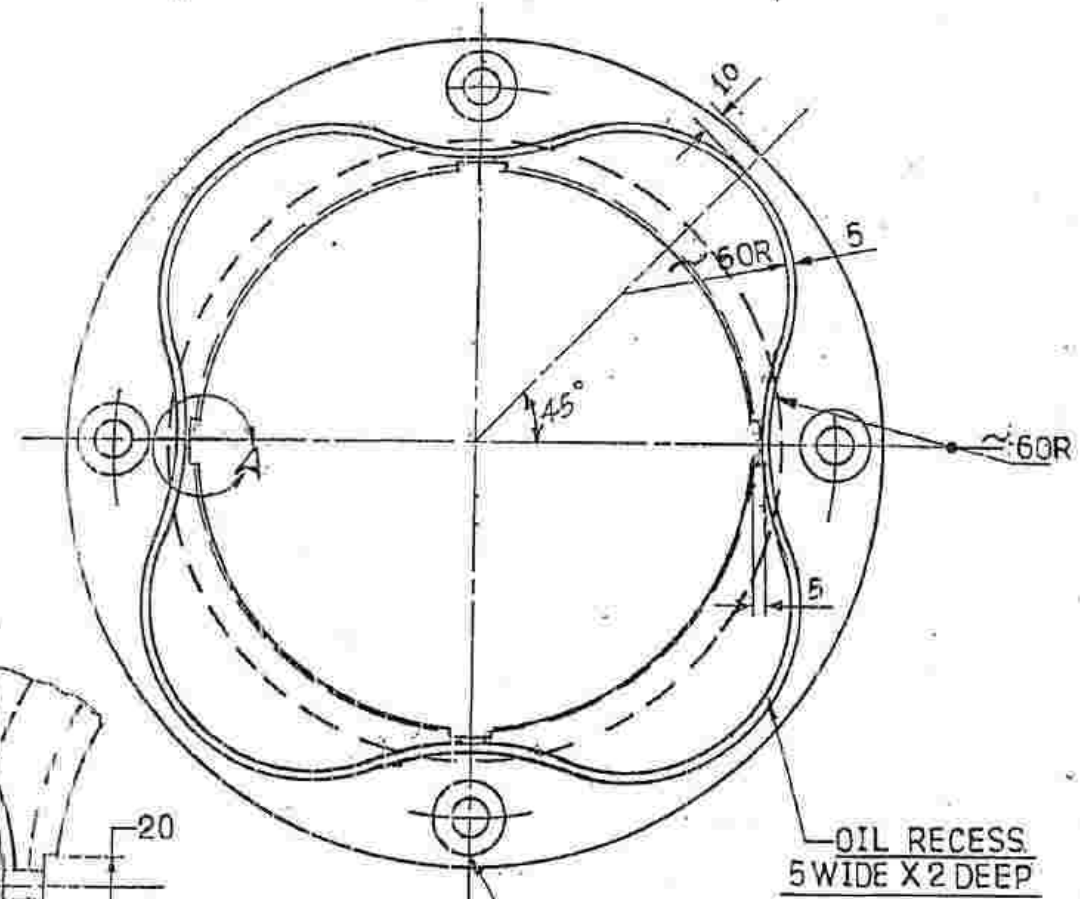
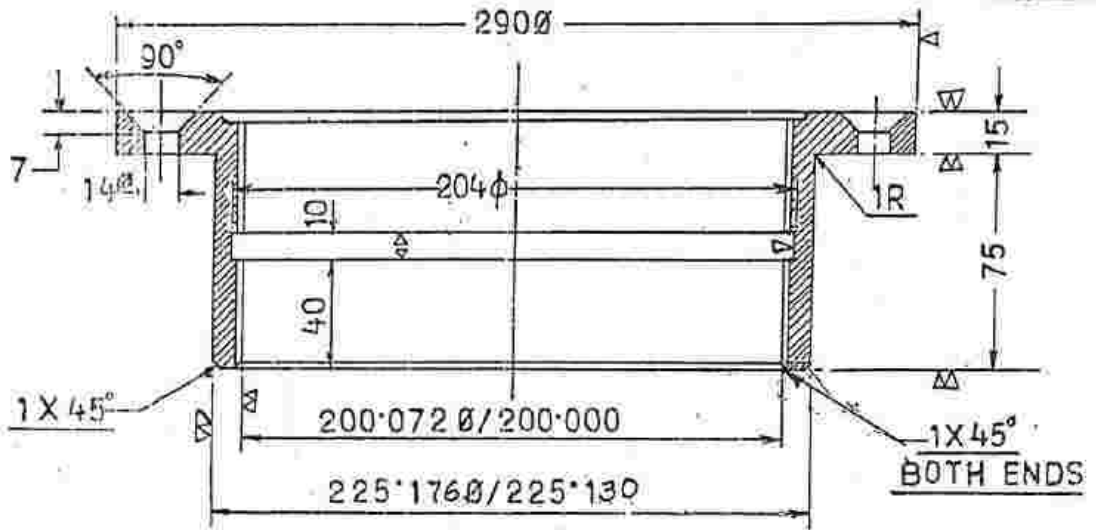

	BUSH FOR CABLE LIFTER		1560.00.602	
			MATERIAL- G.I.C BS:1400	
BUREAU-CHIEF	VIKASH KUMAR	<i>(Signature)</i>	SCALE-1:2.5	WEIGHT IN KG - 10.00
CHECKED BY	VIKASH KUMAR			
DESIGNED BY	NAVESH KUMAR	<i>(Signature)</i>	H.M.B	
1560.00.400	DRAWN BY		V.S. KUMAR	Feb.'20
REF. DRG NO			HEC LTD. RANCHI	
			Rev.-0	

GARDEN REACH SHIPBUILDERS & ENGINEERS LTD. CALCUTTA.		DECK MACHINERY DIVISION	
DRAWN <i>[Signature]</i>	DATE 21.1.89	DESCRIPTION	
TRACED	DATE	NUT	
CHECKED <i>[Signature]</i>	DATE 11.10.89	REV.	
EST. WT. 15 Kgs.		MATERIAL - G.I.C. BS-1400	
		SCALE - 1:2.5	
		SK No. 4'07095	

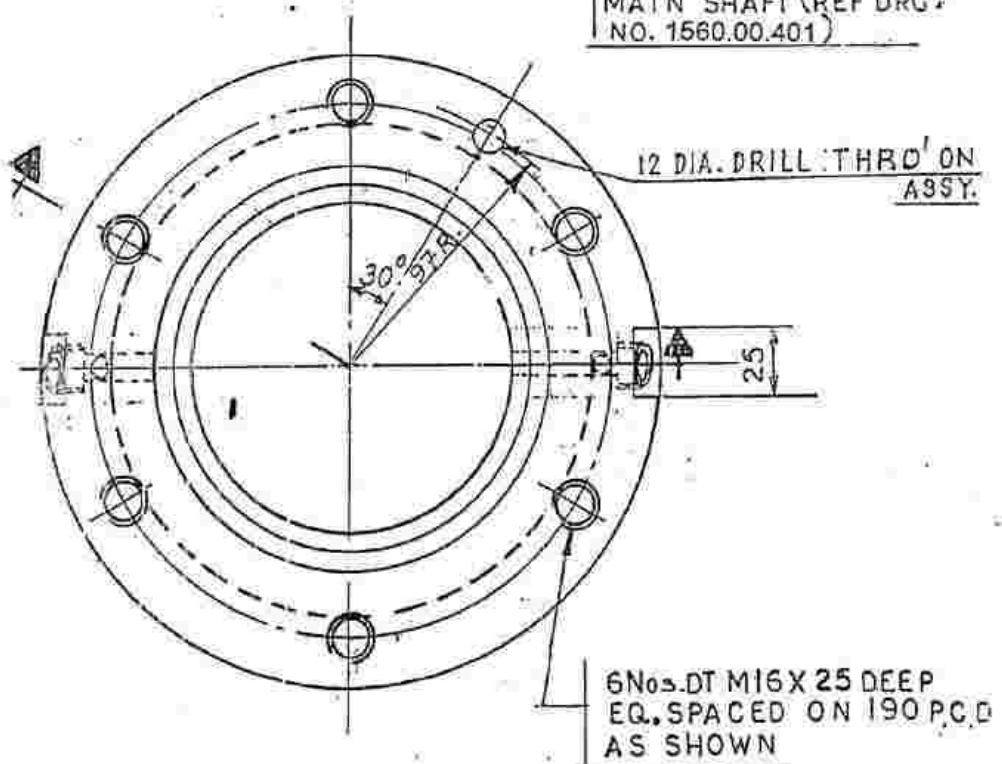
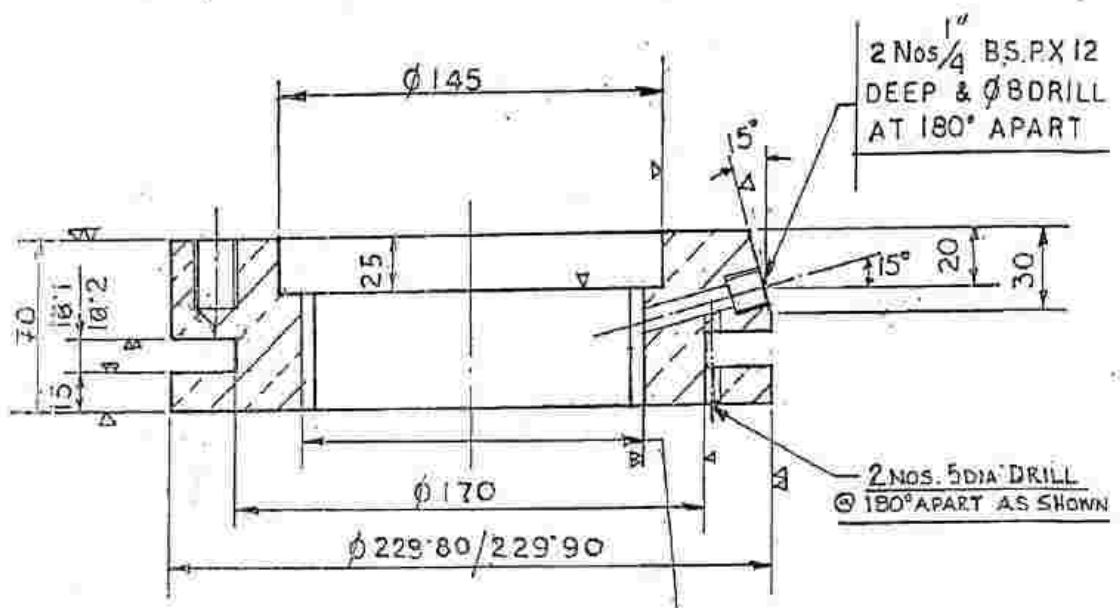

	NUT		1560.00.606	
			MATERIAL - G.I.C. BS:1400	
BUREAU-CHIEF	VIKASH KUMAR	<i>[Signature]</i>	SCALE-1:2.5	WEIGHT IN KG. - 15.00
CHECKED BY	VIKASH KUMAR			
DESIGNED BY	HAVEEN KUMAR	<i>[Signature]</i>	H.M.B	
1560.00.400	DRAWN BY		V.S. KUMAR	Feb.'20
REF. DRG. NO.			HEC LTD., RANCHI	
			Rev.-0	

1560.00.429

25/ the rest

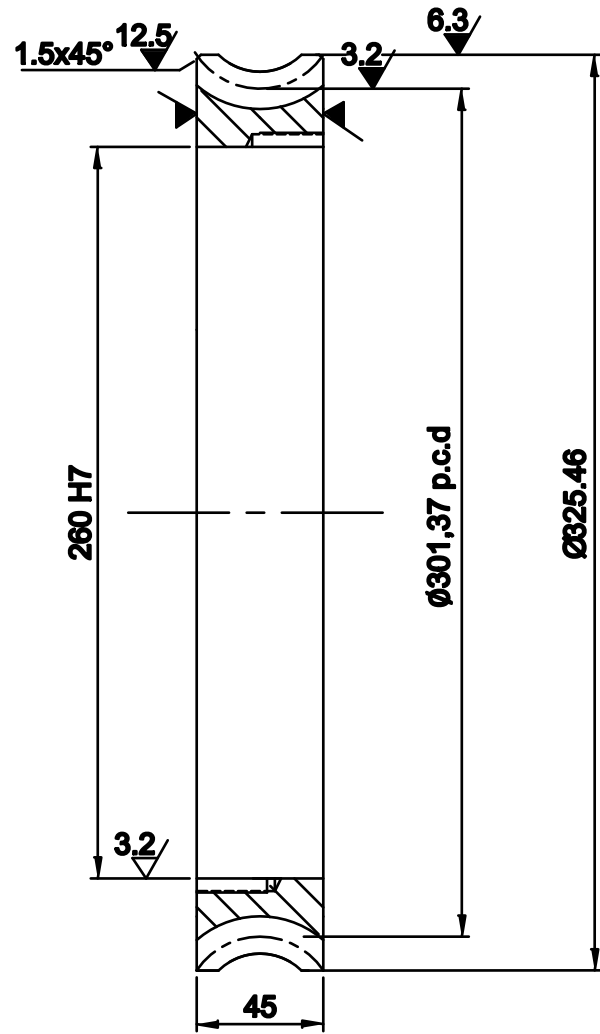

CHEMICAL COMPOSITION OF PB 2C

COPPER - 85.1 - 88.8%
 TIN - 11 - 13%
 ZINC - 0.3%(max.)
 LEAD - 0.5%(max.)
 PHOSPHOROUS- 0.15-0.6%
 NICKEL - 0.5%(max.)
 REMAINING IMPURITIES

**PHYSICAL PROPERTIES OF PB 2C
 CENTRIFUGALLY CAST**

TENSILE STRENGTH - 28Kg/mm2(min.)
 0.2% PROOF STRESS - 17Kg/mm2(min.)
 ELONGATION 5.65 $\sqrt{S_0}$ - 3-14%

NOTE:-

1. Casting to be free from all types of defects.
2. Surfaces marked ∇ to be machined after assembly as per drg.1560.00.428
3. Ovality and taper of fitting dia. to be within half of its diametral tolerance.
4. Sharp edges to be rounded off.

INDEX	NO.	DESCRIPTION	REVISION	SIGNATURE	DATE

 एच. ई. सी.	Worm Gear Rim			1560.00.429	
				MATERIAL- PB 2C BS:1400	
3.07097	BUREAU-CHIEF	V.Kumar	SCALE- 1:2.5	WEIGHT IN KG.- 9.00	
	CHECKED BY	V.Kumar	H.M.B. HEC LTD.,RANCHI		Feb'2020
1560.00.428	DESIGNED BY	N.Kumar			Rev. 0
REF.DRG.NO.	DRAWN BY	V.S.Kumar			

