



ISO 9001 Company

Heavy Engineering Corporation Limited

(A Govt. of India Enterprise)

Heavy Machine Building Plant

MM Division

Tender No- ACD/HMB/17/FAB/2042/OTE-5253

Dtd: 18.01.18

TENDER DOCUMENTS



**Manufacturing, Fabrication, Galvanizing, Supply to HMBP,
Unloading, Storage, Watch & Ward, Erection & Commissioning of
Structural item for DSL System at M/s VSP**

MATERIAL MANAGEMENT DIVISION
HEAVY MACHINE BUILDING PLANT

HEAVY ENGINEERING CORPORATION LIMITED

P.O.-DHURWA, RANCHI

1



ISO 9001 Company

Heavy Engineering Corporation Limited

(A Govt. of India Enterprise)

Heavy Machine Building Plant

MM Division

Tender No- ACD/HMB/17/FAB/2042/OTE-5253

Dtd:18.01.18

INFORMATION

This Tender is invited for Manufacturing, Fabrication, Galvanizing, Supply to HMBP, Unloading, Storage, Watch & Ward, and Erection & Commissioning of Structural item for DSL System in all respect at M/s VSP, Visakhapatnam.

Tender papers can be collected from the office of Sr DGM/I/c/MM/HMBP, ADM building, HMBP, HEC Ltd during all working days from 8 AM to 5 PM up to 08.02.18

1.0 Qualifying Criteria:

- 1.1 The tenderer must have the experience of Design, Manufacturing, Supplying, Erection & Commissioning of similar kind of work in the last five years and must have to execute a single value order of similar kind of work not less than 50 lakhs. (Reference Copy of PO to be submitted along with Part-1 of offer)
- 1.2 Yearly turnover of the firm should not less than 500 lakhs during last financial year i.e. year 2016-17. (Copy of balance sheet of last three year to be submitted along with Part-1 of offer)

2.0 Information to be submitted with the techno-commercial offer:

- 2.1. Experience of similar kind of work executed during the last five years (ref copy of PO/LOA/Work Order to be submitted along with Part-1 of offer). Completion certificate, details/ name of the clients etc are to be mentioned with copy of supporting documents along with the offer.
- 2.2. Documentary evidence of adequate financial standing along with balance sheet and profit & loss statement of last three years i.e. 2014-15, 2015-16 & 2016-17 are to be submitted with the offer.
- 2.3. All tenderers shall submit copy of PAN No., Copy of Income Tax Return of last 3 year, GST Registration No.
- 2.4. Constitution and legal status of the tenderer (individual, partnership, co-operative, registered firm etc), existence of joint ventures or other tie up for technology, equipment, financial backing and/or project management etc to be clearly mentioned with copy of supporting documents along with the offer.
- 2.5. Details of necessary equipments / facilities for the job under this tender to be deployed for the project and proof of its availability, along with details of equipments proposed to be purchased or hired are to be attached with this offer.
- 2.6. Availability of key personnel for supervision and management of the work to be indicated.
- 2.7. Information regarding project in hand, current litigation, orders regarding execution / expulsion or black listing, if any, to be furnished.
- 2.8. Copy of the registration with HEC/ or any other Govt. /semi Govt. Organization, State/Central Govt deptt, Reputed Private Companies are to be attached with the offer.

Note: The final acceptance of the tenderer capability will be assessed by HEC based on the Qualifying Criteria and acceptance of other terms and condition of NIT.

3.0 Deposit of EMD/Tender Fee: Deposit Earnest Money amounting Rs 750000/- & Tender Fee amounting Rs.1500/-

Category of exempted bidders -NSIC/MSE/SSI UNIT, against submission of valid documentary evidence of the same.

Bidders not covered under exemption shall Deposit Earnest Money amounting Rs 750000/- & Tender Fee amounting Rs.1500/- payable by DD in favour of Heavy Engineering Corporation Ltd Payable at Hatia, Ranchi. Non submission of EMD may result in non acceptance of your offer.



ISO 9001 Company

Heavy Engineering Corporation Limited

(A Govt. of India Enterprise)

Heavy Machine Building Plant

MM Division

Last date of submission of tender: ---- 08.02.18 up to 1 PM
Tender Opening date: ---- 08.02.18 at 3 PM

The tender documents are divided in two sections.

Section [I] - COMMERCIAL TERMS AND CONDITIONS

Section [II] - TECHNICAL SPECIFICATION - As Enclosed in Annexure A

NOTE: Any Future changes/notifications including extension of bid due date, pertaining to this tender will be published/hosted only on website & CPP Portal only.

4.0 INSTRUCTIONS TO TENDERER

4.1 Submission of Tender

The complete tender is to be submitted in a separate sealed envelope super scribing the tender no., before the scheduled date of submission of tender in the tender box at the office of Sr.DGM/I/c/MM/HMBP, HMBP ADM Building, HEC Ltd, Ranchi 4.

If the tender is bulky & voluminous the tenders can be submitted at the office of Sr.DGM/I/c/MM/HMBP, HMBP ADM Building, HEC Ltd, Ranchi 4.

The offer is to be submitted in three parts. Part I, Part II & Part III.

Part I- This part will comprise Techno Commercial offer confirming all technical specification, commercial terms and conditions along with Annexure-B and price format as per “Annexure C” with price column blanked. The price format should contain item wise list of items for which the price has been quoted. Full particular i.e. specification, literature and or drawing wherever applicable should be submitted along with the quotation.

Part II- This part will comprise price format duly filled as per Annexure C

1. All the columns of the price format must be filled up by tenderer. The Basic price will be including P & F Charges as the prices asked FOR destination basis.
2. Transportation cost from Ex Works to HMBP, Ranchi shall be in suppliers scope and no charges for the same will be paid by HEC as the basic prices is asked on FOR destination basis.
3. Transit Insurance charges shall be in supplier’s scope and no charges for the same will be paid by HEC as the basic prices is asked on FOR destination basis.

Part III- This part will contain only DD / Bank guarantee for Earnest Money deposit & Tender Fee.

The Demand draft for EMD & Tender Fee should be drawn in favour of Heavy Engineering Corporation Ltd, Ranchi. The DD should be preferably of State Bank of India, payable at Hatia. The EMD can also be submitted in the form of Bank guarantee in HEC’s format as enclosed at Annexure F.

All the three bids i.e. Part-I, Part II & Part III shall be in separate sealed covers clearly super scribing on the top of each envelope the relevant part number, tender reference number with date and due date of opening. Quotation erased or over written are likely to be rejected unless all corrections are authenticated with the tenderer’s signature.



ISO 9001 Company

Heavy Engineering Corporation Limited

(A Govt. of India Enterprise)

Heavy Machine Building Plant

MM Division

Tender No- ACD/HMB/17/FAB/2042/OTE-5253

Dtd:18.01.18

Terms & conditions

5.0 Price. The rate quoted by the tenderer must be firm and the offers may remain valid for acceptance of 180 days from the due date of opening of the tender.

5.1 FOR SUPPLIES :

Prices quoted must be firm till completion of work defined under the scope of supplier. The prices must be quoted in the format as indicated in Annexure-C enclosed herewith.

5.2 Unloading, Storage, Watch & Ward, Erection & Commissioning:

5.2.1 Prices should be quoted on per man rate basis and inclusive of all applicable taxes, duties, levies, expenses towards various statutory and regulatory body and insurance coverage.

5.2.2 Service Tax for supervision of erection and commissioning, if applicable, shall be reimbursed against documentary evidence by PURCHASER. The price also includes all charges towards to and fro travel, boarding, local transportation, medical etc.

5.2.3 Price shall remain firm and binding till completion of work and shall not be subject to any variation whatsoever on any account except for statutory variation on taxes and duties.

5.3 TAXES & DUTIES

Any revised imposition of taxes on the finished items within the purchase order delivery period will be reimbursed by PURCHASER against documentary evidence. Similarly, if any of existing taxes, are reduced or abolished, PURCHASER shall be entitled to get the resultant benefit in full.

5.3.1 Way Bills/ Road Permit :

No consignment shall be despatched by the Supplier without a valid way bill / Road Permit, to be issued by PURCHASER. (If applicable)

5.3.2 FOR ERECTION & COMMISSIONING

All applicable taxes and other charges legally levied on the supplier in connection with this work order are included in the purchase order price and shall be borne and paid by the supplier. The service tax shall be re-imbursed against documentary evidence as applicable.

The supplier shall certify, if required by PURCHASER that due taxes have been paid by him on this order and produce evidence of tax paid which is legally due and payable on this order PURCHASER shall bear no liability in respect of any taxes, duties, levies etc. whatsoever.

Any Indian Income Tax which PURCHASER may be required to deduct by law or statute shall be deducted at source and the same shall be paid to Income Tax / Sales Tax Authorities on account of Supplier. Supplier shall indicate their Permanent Account No. with the relevant Income Tax Authority for this purpose to PURCHASER.

PURCHASER's liability in respect of taxes shall be limited to statutory variations, if any, from date of your final offer submission of documentary evidence.

The Supplier shall produce documentary evidence as may be called for by PURCHASER in respect of taxes paid by the Supplier.

6.0 Acceptance of Tender

Tender may be accepted for full or for part quantity. Any incomplete tender in any respect is liable to be rejected.



ISO 9001 Company

Heavy Engineering Corporation Limited

(A Govt. of India Enterprise)

Heavy Machine Building Plant

MM Division

The tenderers must give their acceptance for part of tendered quantity in case they are successful bidder.

The company is having right to reject any tender without assigning any reason for which no question can be asked anywhere.

There is no obligation on our part to accept delayed / late tender received after the due date of opening of tender and these are liable to be summarily rejected.

The Corporation does not pledge itself to accept the lowest or any tender and reserve to itself the right of accepting the whole or any part of tender or portion of the quantity offered and you shall supply the same at the rate quoted.

7.0 Earnest money and Tender Fee

7.1 Earnest Money - Earnest Money amounting **Rs 7,50,000/-** will have to be deposited by bidder payable by DD in favour of Heavy Engineering Corporation Ltd Payable at Hatia, Ranchi. Exemption of EMD shall be applicable on submission of valid SSI/NSIC/MSME certificate and as per govt rules.

7.2 Tender Fee – Tender Fee amounting **Rs 1500/-** will have to be deposited by bidder payable by DD in favour of Heavy Engineering Corporation Ltd Payable at Hatia, Ranchi.. Exemption of Tender Fee shall be applicable on submission of valid SSI/NSIC/MSME certificate and as per Govt rules.

- DD preferable of State Bank Of India

8.0 Security Deposit

Successful tenderer will have to deposit security deposit equal to 5% of the basic value of the contract within 21 days from the date of award of contract, failing this, the contract will be cancelled and the stores will be procured at the Risk and expenses of the contractor. This will be in addition to other remedies available to the purchaser for the successful completion of the contract as provided in general terms & conditions of the contract of HEC. The validity of the security deposit shall be up to the completion of work under scope.

9.0 Refund of Security Deposit

The security deposit will be refunded within 60 days after successful completion of the Work Order.

10.0 Liquidated Damages (LD)

Delivery : The time for and the date of delivery of the Stores stipulated in the acceptance of tender shall be deemed to be the essence of the Contract and delivery must be completed not later than the dates specified therein. Otherwise:

10.1 The purchaser to recover from the Contractor a sum of 0.5% per week (Completed week) of the price of the Stores (upto maximum 10%) as liquidated damages, which the contractor has failed to deliver as aforesaid or

10.2 The purchaser may procure the undelivered stores/ similar items from elsewhere, without notice to the contractor at the risk of the contractor without cancelling the contract in respect of the consignment not yet due for delivery or

10.3 To cancel the contract or a portion thereof.

11.0 Performance Bank Guarantee

The successful tenderer will have to submit performance bank guarantee amounting 10% of the contract price valid till guarantee period in HEC's format as enclosed at Annexure G after supply of material.



ISO 9001 Company

Heavy Engineering Corporation Limited

(A Govt. of India Enterprise)

Heavy Machine Building Plant

MM Division

12.0 Delivery/Dispatch Schedule

12.1 For Supply :

All material within 75 days from the date of approval of QAP.

12.2 Erection and Commissioning: Within 45 days from the date of receipt/handing over of the material by HEC to firm at VSP.

13.0 Inspection

The structure shall be inspected and tested during different stages of its manufacturing by the authorized representative of M/s VSP / MECON / HEC at the tenderer's works or their sub-vendor's works as well as at VSP site. All facilities and necessary drawings and documents shall be provided to the inspector by the tenderer at the time of inspection. However, this inspection shall not relieve the tenderer from his overall responsibility for correctness of engineering, manufacture, supply, erection & commission to the satisfaction of M/s VSP & their consultant M/s MECON.

The inspection / testing of offered items shall be carried out as per approved Quality Assurance Plan (QAP). All the tests shall be carried out in the presence of M/s VSP / MECON / HEC for which intimation shall be given two weeks in advance.

The successful tenderer shall submit QAP to HEC for approval within 15 days form PO date.

14.0 Submission of Bills

For getting payments supplier has to submit his bill as indicated in payment terms to Sr Mgr/ ACD / MM Div/HMBP.

15.0 Paying Authority

Sr DGM / I/c/ (Fin) / HMBP / HEC

16.0 Payments Terms

Subject to any deduction, which PURCHASER may be authorized to make under the Purchase order, the Purchase order Price shall be payable as follows:

16.1 FOR SUPPLY

A. 90% of the basic price including 100% taxes and duties (GST) through RTGS within 60 days of receipt of material at HMBP Stores on submission of PBG amounting 10% shall be payable against submission of following complete and correct documents in four (4) sets at HEC, Ranchi.

- a) GST Invoice (3 -Original).
- b) Copies of Receipted Lorry Consignment note.
- c) Copies of Packing List / Delivery Challan including originals.
- d) Copies of Inspection Certificate issued by QCA HMBP or MECON /copy of CRV issued by Stores / HMBP.
- e) Despatch clearance issued by PURCHASER.
- f) Copy of intimation to Insurance Company for Transit Insurance.
- g) PBG amounting 10% till guarantee period.

The above payments shall be released on receipt of complete and correct documents as listed above at HEC, Ranchi. The above documents to be submitted within 30 days of generation of invoices, provided it is to be ensured that despatches are made and Invoices are raised strictly as per the order. Number & distribution of above noted despatch documents including original LR are indicated in our Despatch Instructions.



ISO 9001 Company

Heavy Engineering Corporation Limited

(A Govt. of India Enterprise)

Heavy Machine Building Plant

MM Division

In order to avoid detention/ seizure of goods at check post during transit, the Supplier shall send the following documents along with the equipment:

- a) GST Registration Certificate Nos. of PURCHASER
- b) Transporter copy of GST Invoice / Delivery Challan.
- c) Packing List
- d) Consignment note/Lorry Receipt (LR)
- e) Way Bill (if applicable)

In the event or any detention/seizure of goods, the Supplier shall depute his personnel, dealing with sales tax to take up the matter with appropriate authorities to get the goods released. Without prejudice to any other rights as provided in the purchase order, the supplier shall keep PURCHASER harmless and be responsible for any loss/damage/delay etc.

B. Payment of Completion

10% of the Purchase order price shall be paid to Supplier on completion of the work defined under the scope of work and acceptance of the Works by the PURCHASER/ In-charge Marketing or his authorised representative and submission of the following documents in 4 sets to PURCHASER, Ranchi directly.

- a) GST Invoice.
- b) Completion Certificate issued by PURCHASER's site engineer.
- c) Commissioning Certificate issued by PURCHASER's site engineer.
- d) Acceptance of the Works Certificate issued by PURCHASER.

16.2 FOR ERECTION AND COMMISSIONING

100% payment will be made after successful commissioning against receipt of the GST Invoice (with **SAC Code**) along with the commissioning certificate from the PURCHASER's site engineer.

Document required for Payment

1. GST Invoice
2. Commissioning Certificate issued by PURCHASER's site engineer

No advance will be provided to the successful tenderer. The prices are to be firm and any upward revision of taxes shall not be payable.

17.0 Guarantee:

The Successful tenderer shall provide performance guarantee till the issuance of FAC (Final Acceptance Certificate) and shall be liable to take up any modification / alteration required without any extra cost. M/s VSP / MECON / HEC has right to reject & disallow the use of materials, which in his opinion is of sub-standard quality.

18.0 Termination of Order

18.1 The order can be terminated if the supplier fails to deliver the goods in time.

18.2 Any other reason due to which company thinks it fit to terminate the order.



ISO 9001 Company

Heavy Engineering Corporation Limited

(A Govt. of India Enterprise)

Heavy Machine Building Plant

MM Division

18.3 In the event of the termination of the contract in part/ full the company can get the work completed from any other agency/ departmentally at the risk and cost of the supplier.

19.0 MODE OF DESPATCH

By road to the consignee at Incharge, Stores, HMBP, HEC Ltd, Ranchi. For the Consignments to be despatched by Road, the supplier shall ensure that the following are to be observed by them:

- a. All despatches must be effected only on receipt of written despatch clearance from PURCHASER.
- b. You shall despatch all the materials consigned to Incharge, Stores, HMBP, HEC Ltd, Ranchi
- c. Identify and obtain the correct type of trucks/trailers, keeping in view the nature of consignments to be despatched.
- d. Care shall be taken to avoid damages during transit to ensure that all packages are firmly secured.
- e. All consignments despatched by truck/ trailer shall be consigned on door delivery basis (Full or part lorry load). No transshipment is allowed.
- f. The transporter must be approved by Bank Association.
- g. In case any other mode of transport has to be restored other than that mentioned in the Purchase Order, the same should be done only after obtaining prior approval in writing from the Purchaser. By allowing such transportation no increase in freight charges shall be allowed and in case there is decrease, the actual shall be payable to the supplier.

20.0 PACKING, FORWARDING AND SHIPMENT

20.1 The Supplier, wherever applicable, shall after proper painting, pack and crate all equipment in such a manner as to protect them from deterioration and damage during rail and road transportation to the site and storage at the site till the time of erection. The Supplier shall be held responsible for all damages due to improper packing. The supplier shall be liable to deliver the material at the destination as per specification. Any damage during transit shall be sole responsibility of the supplier. In case of damage, the material shall be liable to be rejected and supplier shall replace the same and lift the rejected material within time at their risk and cost.

20.2 The Supplier shall notify the Purchaser of the date of each shipment from his works, and the expected date of arrival at the site for the information.

20.3 The Supplier shall also give all shipping information concerning the weight, size and content of each packing including any other information the Purchaser may require.

20.4 The Supplier shall prepare detailed packing list of all packages and containers, bundles and loose material forming each and every consignment despatched to site. The Supplier shall further be responsible for making all necessary arrangements for loading, unloading and other handling right from his works up to the safe delivery at site store.

21.0 DEMURRAGE, WHARF-AGE, ETC.

All demurrage, wharf-age and other expenses incurred due to delayed clearance of the material or any other reason shall be to the account of the Supplier.

22.0 FORCE MAJEURE

22.1 Force majeure is herein defined as any cause which is beyond the control of the Supplier or Purchaser as the case may be which they could not foresee or with a reasonable amount of diligence could not have foreseen and which substantially affect the performance of the purchase order, such as:



ISO 9001 Company

Heavy Engineering Corporation Limited

(A Govt. of India Enterprise)

Heavy Machine Building Plant

MM Division

- 22.1.1 Natural phenomena, including but not limited to floods, draughts, earthquakes and epidemics:
- 22.1.2 Acts of any government, including but not limited to war, declared or undeclared, priorities, quarantines, embargoes,
- Provided either party shall within fifteen (15) days from the occurrence of such a cause notify the other in writing of such causes.
- 22.2 The bidding document will clearly state that
- 22.2.1 The Supplier will advise, in the event of his having resort to this clause by a registered letter duly certified by the local chamber of commerce or statutory authorities, the beginning and end of the clause of delay, within fifteen days of the occurrence and cessation of such force majeure condition. In the event of delay lasting over two months, it arising out of force majeure, the purchase order may be terminated at the discretion of the company.
- 22.2.2 For delays arising out of Force Majeure, the Supplier will not claim extension in completion date for a period exceeding the period of delay attributed to causes of Force Majeure and neither PURCHASER nor the Supplier shall be liable to pay extra costs (like increase in rates, remobilization advance, idle charges for labour, machinery etc.) provided it is mutually established that the Force Majeure conditions did actually exist.
- 22.2.3 If any of the Force Majeure conditions exists in the place of operation of the Supplier even at the time of submission of the bid he will categorically specify them in the bid and state whether they have been taken into consideration in their quotations.
- 22.2.4 The Supplier or the Purchaser shall not be liable for delays in performing his obligations resulting from any force majeure cause as referred to and/or defined above. The date of completion will, subject to hereinafter provided, be extended by a reasonable time even though such cause may occur after Supplier's performance of his obligations has been delayed for other causes.
- 23.0 **MARKING OF EQUIPMENT :**
The materials must be marked/stencilled of Equipment No. The word ----- should be engraved
- 24.0 **NOTIFICATION OF DESPATCH :**
Each and every despatch should be notified immediately after despatch giving the relevant particulars like Truck No., Invoice/Challan No. with date, C/Note No., Name of the transporter with their full address, date of despatch etc. to the person who signatures the order through fax / e-mail :
- 25.0 **PROGRESS REPORT:**
Progress of delivery/inspection must be given to the officer who has signed the purchase order, on the 15th and 30th of each month during currency of delivery period. Where delivery period is crossed by the supplier, he has to take approval of buyer in writing before despatch.
- 26.0 **SUBLETTING AND ASSIGNMENT :**
The supplier shall not, have without the previous consent in writing of the purchasers, sublet, transfer or assign the purchase order or any part thereof or interest therein or benefit or advantage thereof in any manner whatsoever. Provided nevertheless that any such



ISO 9001 Company

Heavy Engineering Corporation Limited

(A Govt. of India Enterprise)

Heavy Machine Building Plant

MM Division

consent shall not relieve the supplier from any obligation, duty or responsibility under the purchase order.

27.0 **CHANGE IN A FIRM :**

Where the supplier is a partnership firm, a new partner shall not be introduced in the firm except with the previous consent in writing of the purchaser (which may be granted only as an exception) of a written undertaking by the new partner to perform the purchase order and accept all liabilities incurred by the firm under the purchase order prior to the date of such undertaking.

On the death or retirement of any partner of the supplier's firm before complete performance of the purchase order, the purchaser may at this option cancel the purchase order. In such case the supplier shall have no claim whatsoever to compensation against the purchaser.

If the purchase order is not determined as provided above notwithstanding the retirement of a partner from the firm he shall continue to be liable under Section 32 of the Partnership Act has been sent by him to the purchaser by registered post acknowledgement due.

28.0 **CONSEQUENCE OF BREACH :**

Should the supplier or a partner in the supplier firm commit breach of either of the clauses (21) and (22) of this commercial terms and conditions, it shall be lawful for the purchaser to cancel the purchase order and purchase or authorize the purchase of the stores at the risk and cost of the supplier firm and that even the provisions of Clause (12) shall, as far as applicable, apply.

The decision of Heavy Engineering Corporation Limited as to any matter or thing concerning or arising out of this clause or any question whether the supplier or any partner of the supplier firm has committed a breach of any of the conditions in this clause contained shall be final and binding on the supplier.

29.0 **CONSIGNEE:**

Incharge Stores
HMBP/ HEC Ltd / Ranchi
JHARKHAND

30.0 **Q.A. PLAN**

Approved QAP and inspection procedure by M/s VSP/HEC/MECON shall apply.

31.0 **WEIGHT OF EQUIPMENT**

Weight of each equipment must be intimated to the purchaser before effecting delivery.



ISO 9001 Company

Heavy Engineering Corporation Limited

(A Govt. of India Enterprise)

Heavy Machine Building Plant

MM Division

32.0 FORMAT AND NAME PLATE

All the drawings should be prepared in the format and nameplates with drawing No. out of allotted drawing Nos. to be given to you at the time of placement of order.

33.0 DRAWING, DOCUMENTS & MANUALS

Will be furnished as per Technical Specification.

34.0 UNIT RATES

Unit rates of various supply items which may be required during execution of this package will remain firm till execution of the order.

35.0 BOUGHT-OUT ITEMS:

Un-priced purchase order of your bought-out items will be submitted to us within a week after issue of your order.

36.0 PAINTING

Painting will be done as per Technical Speciation.

37.0 REJECTION

If the stores supplied are not up to specifications/samples or in accordance with order and are rejected, the same will be removed by you at your own risk and cost within 21 days of the date of intimation of rejection by Inspection Deptt/Stores Deptt/Purchase Deptt. If no instruction are received from you with regard to mode of despatch back to you, we shall be free and reserve the right to return the rejected materials at your risk and cost and to recover entire freight and other incidentals incurred by PURCHASER. Such rejected stores will be kept in our go down/site for 21 days from the date of intimation to you and thereafter they remain at your risk and cost. The purchaser shall also be entitled to recover ground rent/demurrage charges on the rejected stores after expiry of free time mentioned above.

38.0 SPECIAL INSTRUCTION (DESPATCH MARK/ INDENTIFICATION MARK)

The following markings are to be done on each package

a)	From	
b)	For	
c)	Case No.	The case no. shall be written in the form of a fraction the numerator of which shall be serial number of the case and the denominator representing the total number of cases.
d)	Order No.	
e)	Net Weight	
f)	Gross Weight	

39.0 LEGALITY AND DISPUTE SETTLEMENT :

39.1 This order/purchase order shall be governed by and interpreted according to the relevant laws of India with jurisdiction of courts at Ranchi.



ISO 9001 Company

Heavy Engineering Corporation Limited

(A Govt. of India Enterprise)

Heavy Machine Building Plant

MM Division

- 39.2 Any dispute that may arise between the parties out of or in-connection with this order/purchase order or for the breach thereof, shall be settled amicably and in good faith by negotiations between the designated executives of the parties, at the first instance.
- 39.3 In the event, the parties fail to resolve the disputes or differences arising out of or in connection with the order/purchase order or execution thereof through amicable settlement, the same shall be referred to settlement through “adjudication” of the same by the Sole Arbitrator appointed by PURCHASER. Such arbitration shall proceed as per the provisions of Arbitration and Conciliation Act, 1996 and /or amended from time to time.
- 39.4 The arbitration shall be governed by and in accordance with the Arbitration and Conciliation Act, 1996 for adjudication of the disputes and differences including claims and counter-claims of the parties. The award rendered shall be final and binding upon both the parties.
- 39.5 The cost of the arbitration proceedings shall be borne by the parties on pro-rata to this purchase order value.
- 39.6 The venue of arbitration shall be normally at Ranchi only, unless and until agreed otherwise by the parties.
- 39.7 The Jharkhand High Court shall have the exclusive jurisdiction in respect of the order/purchase order.

40.0 **OTHER TERMS AND CONDITIONS**

Other terms and conditions which are not mentioned above shall be as per General Terms and Conditions of Contract of the Corporation which can be downloaded from our website (www.hecltd.com).

(S.K.Singh)
Sr.Mgr/ACD/HMBP

Enclosures:

1. Scope of Work (Annexure-A)
2. Check List for Acceptance/Confirmation of Commercial Terms & Conditions (Annexure-B)
3. Format for Price Schedule (Annexure-C)
4. Forms of Tender(Annexure-D)
5. Format for deviation to the technical specification & Commercial terms (Annexure-E).
6. Pro forma for BG for EMD (Annexure -F)
7. Pro forma for BG for Performance Guarantee (Annexure -G)

Note:

- a) Price should be quoted in words and numeral without any cutting and overwriting. The price appearing in words will be binding on both the parties.
- b) Item wise price are Mandatory.



ISO 9001 Company

Heavy Engineering Corporation Limited
(A Govt. of India Enterprise)
Heavy Machine Building Plant
MM Division

Tender No- ACD/HMB/17/FAB/2042/OTE-5253

Dtd:18.01.18

Annexure-A

Scope of Supplies & Works at Site for DSL Structure, COB #5, VSP

The scope of work includes Manufacturing, Fabrication, Galvanizing (hot dip galvanized with a minimum thickness of coating of 90 microns confirming to IS:4759-96, IS:2629-96 & IS:2633-92) & Supply to HMBP store/HEC. Transportation from HMBP's Store to HEC (purchaser's) store at VSP is in HEC's scope. However, receipt, unloading at purchaser's store at VSP, storage, watch & ward, loading and transportation from Purchaser's store at M/S VSP to erection site of Wagon Handling System, Erection, minor site painting (if any) & commissioning of Structural Items for DSL System of COB#5 project at VSP, Visakhapatnam is also included in the scope of work.

Since the work is on Turnkey basis, Welding sets, Manpower, Mobile cranes and all other resources required for the completion of erection & commissioning of Structure of DSL system at site are included in the tenderer's scope.

Any Item not specifically mentioned in the tenderer's scope but required for completeness of erection, & commissioning of structure of DSL system shall deemed to be included in the tenderer's scope, whether specifically mentioned in the scope of work or not.

The detailed scope of work under this tender will generally include the following.

Structure of DSL System for COB #5 Project

Approx Length of DSL- 1=1135.73m, Approx Length of DSL-2= 1115.035 m

Approx total length of DSL=2250.765 m, size (Length) of girders varies from 02 mtrs to 13.845 mtrs.

Tentative gross weight of the structures of the DSL system.

Sl. No.	Item	Weight Approx./Unit	Number/Length in mtr.	Approx Total Weight in (Kg.)
1.	Column	490Kg	218 Nos	106820
2.	Girder	690 Kg (Average Wt.)	L=10.5 (206 Nos) *Others = 10 Nos	149040
3.	Ladder	75 Kg	25 Nos	1875
4.	Grating	16 Kg/m	2270 m	36320
5.	Hand Railing	12.1 Kg/m	4500 m	54375
6.	Zinc Coated Fasteners (Bolt, Nut & Washers)			1570
	Total Weight in Kg			350000



ISO 9001 Company

Heavy Engineering Corporation Limited
(A Govt. of India Enterprise)
Heavy Machine Building Plant
MM Division

*Others : L=8.52 (1 No.), L=11.215 (2 Nos), L=13.85 (1 No.) L=10.145 (1 No.)
L=2.0 (2 Nos), L=7.66 (1 No.), L=7.68 (1 No), L=13.485 (1 No)

Specification of fastners are given below:

Sl. No.	Item	Material/Property Class (PC)	Quantity (in nos)
1.	Hex Head Bolt M20x80	PC8.8, Is:1364-92	3800
2.	Hex Nut 20	Pc 8, IS:1364-92	3800
3.	Flat End Spring Washer 20	Spr. Steel, IS:4072-72	950
4.	Taper Washer 22 for ISMC 150	Mild Steel, IS:5372-75	2850
5.	Hex Screw m10 x35	PC 8.8, Is:1364-92	300
6.	Hex Nut 10	PC 8, IS:1364-92	300
7.	Flat End Spring Washer 10	Spr. Steel, IS:4072-72	300

Schematic drawings for columns & G.A girders is enclosed herewith, however, final drawings shall be given to successful bidders. Details of drawings (for quotation purpose) being provided are as under:

1. Drawings of column - Drg. No. 1520.26.031
2. Drawings of girders for 10.5 m length Drg. No. 1520.26.032
3. Drawing for Misc items such as Ladder, Grating & HR etc-SK 3200.01.471
4. Drawing of location of Columns -SK 3200.01.472

Tender drawings as enclosed with enquiry specifications are for reference only.

All fabrication work shall be in accordance with IS:800-1984 and as per the drawings supplied by HEC unless otherwise specified. The tolerance in fabrication shall be in accordance with IS: 7215-1974, unless otherwise specified. The welding and the welded work shall generally conform to IS: 816-1969 and IS:9595-1996.

All materials used for fabrication in the subject package shall be strictly as per drawings.

The structure shall be inspected and tested during different stages of its manufacturing by the authorized representative of M/s VSP / MECON / HEC at the tenderer's works or their sub-vendor's works as well as at VSP site. All facilities and necessary drawings and documents shall be provided to the inspector by the tenderer at the time of inspection. However, this inspection shall not relieve the tenderer from his overall responsibility for correctness of engineering, manufacture, supply, erection & commission to the satisfaction of M/s VSP & their consultant M/s MECON.



ISO 9001 Company

Heavy Engineering Corporation Limited
(A Govt. of India Enterprise)
Heavy Machine Building Plant
MM Division

The inspection / testing of offered items shall be carried out as per approved Quality Assurance Plan (QAP). All the tests shall be carried out in the presence of M/s VSP / MECON / HEC for which intimation shall be given two weeks in advance.

The Successful tenderer shall provide performance guarantee till the issuance of FAC (Final Acceptance Certificate) and shall be liable to take up any modification / alteration required without any extra cost.

M/s VSP / MECON / HEC shall have right to Inspect all such materials / equipment and the tenderer shall produce these, if so desired by the M/s VSP / MECON / HEC for his inspection. M/s VSP / MECON / HEC has right to reject & disallow the use of materials, which in his opinion is of sub-standard quality.

The tenderer should follow the safety rules of M/s VSP and shall take clearance from the safety, department of M/s VSP or the authorized person of M/s VSP/I MECON / HEC before starting of erection work.

M/s VSP / MECON / HEC shall have free access at all reasonable times to the tenderer's works, where the fabrication is carried out and shall be offered all reasonable facilities by the tenderer to satisfy himself that the fabrication is being undertaken in accordance with provision of drawings & specification. The tenderer shall continually inform M/s VSP/I MECON / HEC of the progress in fabrication and as to when the fabricated items are ready for inspection. Such inspection call shall necessarily be accompanied by the respective reports of internal stage inspection / subsequent rectification report carried out by the tenderer. During inspection, defects which may appear in fabrication shall be made good with the consent of and according to the procedure laid down by M/s VSP / MECON / HEC.

NOTE: Any changes or modification in drawing as per site requirement during erection at site will be suitably modified/ corrected and no claim of extra work shall be considered.



ISO 9001 Company

Heavy Engineering Corporation Limited
(A Govt. of India Enterprise)
Heavy Machine Building Plant
MM Division

Tender No- ACD/HMB/17/FAB/2042/OTE-5253

Dtd: 18.01.18

ANNEXURE – B

(To be filled by the tenderer)

CHECK LIST FOR ACCEPTANCE / CONFIRMATION OF COMMERCIAL TERMS & CONDITIONS

Please confirm your acceptance of following Clauses of Commercial Terms & Conditions:-

Clause No.	PARTICULARS	ACCEPTANCE / CONFIRMATION OF TENDERER AS PER NIT (YES / NO)	REMARKS
1.0	QUALIFYING CRITERIA		
2.0	INFORMATION TO BE SUBMITTED WITH THE TECHNO-COMMERCIAL OFFER		
3.0	DEPOSIT OF EMD/TENDER FEE		
4.0	INSTRUCTIONS TO TENDERER		
5.0	PRICE		
6.0	ACCEPTANCE OF TENDER		
7.0	EARNEST MONEY AND TENDER FEE		
8.0	SECURITY DEPOSIT		
9.0	REFUND OF SECURITY DEPOSIT		
10.0	LIQUIDATED DAMAGES (LD)		
11.0	PERFORMANCE BANK GUARANTEE		
12.0	DELIVERY/DISPATCH SCHEDULE		
13.0	INSPECTION		
14.0	SUBMISSION OF BILLS		
15.0	PAYING AUTHORITY		
16.0	PAYMENTS TERMS		
17.0	GUARANTEE		
18.0	TERMINATION OF ORDER		
19.0	MODE OF DESPATCH		
20.0	PACKING, FORWARDING AND SHIPMENT		
21.0	DEMURRAGE, WHARF-AGE, ETC		
22.0	FORCE MAJEURE		
23.0	MARKING OF EQUIPMENT		
24.0	NOTIFICATION OF DESPATCH		
25.0	PROGRESS REPORT		
26.0	SUBLETTING AND ASSIGNMENT		
27.0	CHANGE IN A FIRM		



ISO 9001 Company

Heavy Engineering Corporation Limited

(A Govt. of India Enterprise)

Heavy Machine Building Plant

MM Division

28.0	CONSEQUENCE OF BREACH		
29.0	CONSIGNEE		
30.0	Q.A. PLAN		
31.0	WEIGHT OF EQUIPMENT		
32.0	FORMAT AND NAME PLATE		
33.0	DRAWING, DOCUMENTS & MANUALS		
34.0	UNIT RATES		
35.0	BOUGHT-OUT ITEMS		
36.0	PAINTING		
37.0	REJECTION		
38.0	SPECIAL INSTRUCTION (DESPATCH MARK/ INDENTIFICATION MARK)		
39.0	LEGALITY AND DISPUTE SETTLEMENT		
40.0	OTHER TERMS AND CONDITIONS		



ISO 9001 Company

Heavy Engineering Corporation Limited
(A Govt. of India Enterprise)
Heavy Machine Building Plant
MM Division

Tender No- ACD/HMB/17/FAB/2042/OTE-5253

Dtd: 18.01.18

Annexure-C
(Price Bid)

No.....

Date :

To,

The Sr. Manager/ACD/HMBP
HMBP,.HEC Ltd.,
Ranchi- 834 004

Dear Sir,

In response to your enquiry for given scope of work. We are giving herewith our best offer without any deviation or rebate:-

Table-1

Sl.No.	Description	Qty.(Kg)	Rate/Kg (Rs.)	Total Amount(Rs.)	GST Rate	GST Value	G Total
		A	B	C=AxB	D	E	F=C+E
01	Manufacturing, Fabrication, Galvanizing, Supply Of Complete DSL, Structures For HMBP Store At Ranchi (Breakup as per table 2)	350000					
02	Material Receipt, Unloading , Storage, Watch & Ward, Transportation, Erection & Commissioning Of Complete DSL Structure at M/s VSP Site	350000					
	Total						

Total price in Words-_____.



ISO 9001 Company

Heavy Engineering Corporation Limited
(A Govt. of India Enterprise)
Heavy Machine Building Plant
MM Division

Table 2 (Breakup of price)

Sl. No.	Item	Weight Approx./Unit	Number/Length in mtr.	Approx Total Weight in (Kg.)	Unit Rate Rs./Kg	Total Price (in Rs)
1.	Column	490Kg	218 Nos	106820		
2.	Girder	690Kg (Average Wt.)	L=10.5 (206Nos) *Others=10 Nos	149040		
3.	Ladder	75 Kg	25 Nos	1875		
4.	Grating	16 Kg/m	2270 m	36320		
5.	Hand Railing	12.1 Kg/m	4500 m	54375		
6.	Zinc Coated Fasteners (Bolt, Nut & Washers)	-	-	1570		
	Total			350000		

Total price in Words-_____.

(Name of the Tenderer with Official Seal)

Important :-

1. Rate must be given in figure as well as in words.
2. The tender should be type written.
3. Hand written tender will not be accepted.



ISO 9001 Company

Heavy Engineering Corporation Limited
(A Govt. of India Enterprise)
Heavy Machine Building Plant
MM Division

Tender No- ACD/HMB/17/FAB/2042/OTE-5253

Dtd:18.01.18

Annexure-D

FORMS OF TENDER

Sub : TENDER for the Work _____

To,

Sr. Mgr/ ACD/HMBP
HMBP Administrative Building
Heavy Engineering Corporation Ltd., Ranchi – 834 004(Jharkhand)

Dear Sir,

We offer to execute the Works described above in accordance with the Conditions of Contract accompanying the Tender Document issued to us.

This tender and your written acceptance of it shall constitute a binding contract between us. We understand that you are not bound to accept the lowest or any tender you received.

We hereby confirm that this tender complies with the tender validity and tender security required by the tender documents.

Yours faithfully

Authorised Signature :
Name and Title of the Signatory:
Name of Tenderer :
Address:
Date:



ISO 9001 Company

Heavy Engineering Corporation Limited
(A Govt. of India Enterprise)
Heavy Machine Building Plant
MM Division

Tender No- ACD/HMB/17/FAB/2042/OTE-5253

Dtd: 18.01.18

Annexure-E

Date :

TTO,

o

·Sr. Mgr/ACD/HMBP.

HMBP Administrative Building

Heavy Engineering Corporation Ltd., Ranchi – 834 004(Jharkhand)

Dear Sir,

I have gone through the contents of the Tender Document and the following clause of the document are not acceptable to me and the deviations are as below :-

Sl No	Clause No	Amendment

(Signature of Tenderer) With official Seal

Note :

If any new clause is to be incorporated then that may be mentioned in this schedule. If no amendment is proposed or new clause be incorporated then the tenderer should write nil.



ISO 9001 Company

Heavy Engineering Corporation Limited
(A Govt. of India Enterprise)
Heavy Machine Building Plant
MM Division

Annexure-F

FORMAT OF BANK GURANTEE FOR EARNEST MONEY DEPOSIT

(TO BE STAMPED IN ACCORDANCE WITH STAMP ACT & TO BE ISSUED BY ANY NATIONALISED /SCHEDULED BANK AUTHORISED BY RBI TO ISSUE A BANK GUARANTEE)

NO. Dated:

TO
HEAVY ENGINEERING CORPORATION LTD. RANCHI-834004, JHARKHAND
INDIA

Dear Sirs,

In consideration of your agreeing to accept the Earnest money deposit of Rs.------(Rs-----
-----) furnishable to you by M/s-----
------(Hereinafter Referred to As Contractor) In terms of the Enquiry No. -----
----- Dtd. ----- for Supply of ----- (Hereinafter Referred to
as the Contract) in the form of a Bank Guarantee in the Manner hereinafter contained we -----
-----, having registered office at -----do hereby
covenant and agree with you as follows.

1. We hereby undertake to indemnify you up to a sum of Rs. ----- (Rs. -----
----- only) against any loss or damage caused to or suffered by you or that may be caused to or
suffered by you by reason of any breach or breaches on the part of the contractor of any of the term s and
conditions contained in the said contract and in the event the Contractor shall make any default or defaults
in carrying out any of the works under the said contract or otherwise in the observance and performance
of any of the terms and conditions relating thereto in accordance with the true intent and meaning
thereof, we shall forthwith on demand and without any protest or demur pay to you such sum or sums not
exceeding in total the said sum of Rs.----- (Rs. -----only) as may be
claimed by you as your losses and/or damages, costs, charges or expenses by reason of such default or
defaults on the part of the contractor.

2. Not withstanding anything to the contrary contained in this guarantee your decision a s to whether the
contractor has made any such default or defaults and the amount or amounts to which you are entitled by
reasons thereof will be binding on us and we shall not be entitled to ask you to establish your claim or
claims or damages or losses suffered by you but will pay the amount demanded by you under this
guarantee forthwith without any protest or demur.

3. This guarantee shall continue and hold good until it is released by you on the application by the
contractor after expiry of the related warranty period of the said contract and after the contractor have
discharged all their obligations under the said contract and produced a certificate of due completion of the
work under the said contract and submitted a "NO Demand Certificate" provided always that this
guarantee shall in no event remain in force after the date of----- without prejudice to your claim or
claims arisen and demanded from or otherwise notified to us in writing before the expiry of six months



ISO 9001 Company

Heavy Engineering Corporation Limited
(A Govt. of India Enterprise)
Heavy Machine Building Plant
MM Division

from the said date which will be enforceable against us notwithstanding that the same is or are enforced after the said date.

4. We-----, further undertake to extend the validity of this beyond the period prescribed in clause 3 or as extended from time to time for such further period as may be required in writing before the Expiry of this and upon such extension(s), all terms and conditions of this shall remain in full force till the expiry of this extended period(s).

5. You will have the fullest liberty without affecting this guarantee from time to time to vary any of the terms and conditions of the said contract or extend the time of performance of the contractor or to postpone for any time or from time to time any of your rights or powers against the contractor and either to enforce or forbear to enforce any of the terms and conditions of the said contract and we shall not be released from our liability under this guarantee by the exercise of your liberty with reference to matters afor esaid or by reason of any time being given to the contractor or any other forbearance, act or omission on your part or any indulgence by you to the contractor or by any other variation or modification of the said contract or any other act, matter or things whatsoever, which, under the law relating to sureties, would but for the provisions hereof, have the effect of so releasing us from our liability hereunder provided always that nothing herein contained will enlarge our liability hereunder beyond the limit of Rs. --
------(Rs.-----) as aforesaid or extend the period of the guarantee beyond the said Date of -----unless expressly agreed to by us in writing in terms of clause 4 hereof.

6. This guarantee shall not in any way be affected by your taking or varying or giving up any securities from the contractor or any other person, firm or company on its behalf or by the winding up, dissolution, insolvency or death as the case may be of the contractor.

7. In order to give full effect to the guarantee herein contained, you shall be entitled to act as if we are your principal debtors in respect of all your claims against the contractor hereby guaranteed by us as aforesaid and we hereby expressly waive all our rights of suretyship and other rights, if any, which are in any ways inconsistent with any of the provisions of this guarantee.

8. Subject to the maximum limit of our liability as aforesaid this guarantee will cover all your claim or claims against the contractor from time to time arising out of or in relation to the said contract and in respect of which your claim in writing is lodged on us before expiry of six months from the date of expiry of this guarantee.

9. Any notice by way of demand or otherwise hereunder shall be in writing and may be sent by registered post or Telefax to us at our Local Address as aforesaid.

10. This guarantee and the powers & provisions herein contained are in addition to and not by way of limitation or substitution for any other guarantee or guarantees heretofore given to you by us whether jointly with others or alone and now existing uncanceled and that this guarantee is not intended to and shall not revoke or limit such guarantee or guarantees.



ISO 9001 Company

Heavy Engineering Corporation Limited
(A Govt. of India Enterprise)
Heavy Machine Building Plant
MM Division

11. This guarantee shall not be affected by any change in the constitution of the contractor or us nor shall it be affected by any change in your constitution or by any Amalgamation or absorption thereof or therewith but will ensure for the benefit or and be available to and enforceable by the absorbing or amalgamated company or concern.

12. This guarantee is irrevocable during the period of its currency and shall not be revoked without your previous consent in writing.

13. We further agree and undertake to pay you the amount demanded by you in writing irrespective of any dispute or controversy between you and the contractor or any reference to arbitration of the said dispute/controversy pending or a civil suit filed by the contractor in respect of the dispute or controversy.

14. Notwithstanding anything contained herein above our liability under this guarantee is restricted to Rs. ----- (Rs. -----only) and this guarantee shall remain in force until -----unless a written claim is lodged on us for payment under this guarantee within six months from the date of expiry of this guarantee . i.e. On or before-----all your rights under this guarantee shall be forfeited and we shall be deemed to have released and discharged from all liabilities there under, irrespective of whether or not the original guarantee is returned to us.

15. We have power to issue this guarantee in your favour under the memorandum and articles of association of the bank and the undersigned has full power to execute this guarantee under the power of Attorney Granted to us by the Bank.

FOR AND ON BEHALF OF



ISO 9001 Company

Heavy Engineering Corporation Limited

(A Govt. of India Enterprise)

Heavy Machine Building Plant

MM Division

ANNEXURE-G

FORMAT OF PERFORMANCE BANK GUARANTEE

(TO BE STAMPED IN ACCORDANCE WITH STAMP ACT & TO BE ISSUED BY ANY NATIONALISED /SCHEDULED BANK AUTHORISED BY RBI TO ISSUE A BANK GUARANTEE)

Name of Equipment: ----- Gurantee NO----- Purchase Order No.:-----
----- dated: ----- Date:----- Validity -----
Claim period-----

To:

M/s Heavy Engineering Corporation Ltd. Heavy Machine Building Plant
Ranchi-834004 Jharkhand

In consideration of your having placed an order bearing Purchase Order No.-----dated:----- with
----- (hereinafter referred to as Supplier) for the supply of-----
----- (hereinafter referred to as the-----

We ----- do hereby agree with you irrevocably that, should the machinery and equipment fail to give the guarantee performance and achieve the efficiency as stipulated in the Purchase Order within the period of guarantee or should the material and/or workmanship of the machinery and equipment supplied or any part thereof be found defective and/or fully, as per the purchase order, we undertake to pay without any demur merely on demand a sum of Rs. --
-----being 10% of the value of Rs. -----
-----for the supply of -----

Your decision whether the supplier have made any such defaults and the amount to which you are entitled by reasons thereof shall be conclusive and bind on us, subject to maximum of Rs. -----
----- as aforesaid.

We-----further guarantee that the machinery and equipment manufactured and supplied by the supplier shall be new, of good quality materials and of the first class workmanship as specified in the Purchase order and should the machinery and equipment supplied or any part thereof be found defective and that should the defect as pointed out in inspection note be not made good and/or in case of failure within guarantee period same shall be replaced on free of cost or repaired on free of cost to the entire satisfaction of Heavy Engineering Corporation Ltd..

We -----agree that the guarantee herein contained shall remain in full force and effect till the machinery and equipment give the desired performance and it shall continue to be enforceable till your dues have been fully paid and claims satisfied or discharged subject to a period not later than----- . In the event of any extension granted for commissioning/dispatch suitable extension shall be given on your request.



ISO 9001 Company

Heavy Engineering Corporation Limited

(A Govt. of India Enterprise)

Heavy Machine Building Plant

MM Division

We-----, further agree that any neglect, omission or forbearance or indulgence in enforcing any claim as per the terms and conditions of your purchase order or performance guarantee or any of them or any extension of the time granted for the performance or payment of penalty under the guarantee or any dispute between the supplier and yourselves as regard performance of machinery and equipment supplied or issued related to your Purchase order, shall not effect in any way our liability under this guarantee until the full payment, but in any case, shall not extend beyond-----.

This guarantee is in addition and not substitution for guarantee given to you by the seller or by their bankers on their behalf.

We----- lastly undertake not to revoke this bank guarantee during its currency except with the previous consent of the corporation in writing.

Notwithstanding anything to contrary stated above, our liability under this guarantee will be restricted to Rs.----- and shall remain in force up to -----, unless a demand or claim under this guarantee is made from the date i.e. on or before-----all your rights under the said guarantee shall be forfeited and we shall be released and discharged from all liabilities thereunder.

Dated at ----- day of -----

Seal of the Bank

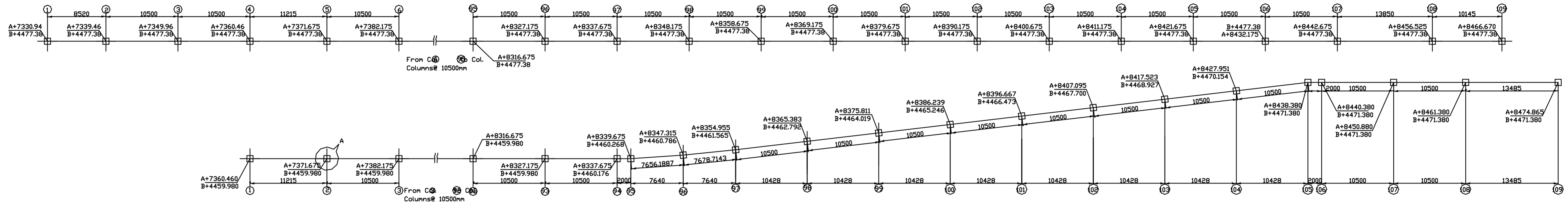

Plan

This drawing is indicative only and has been prepared for Quotation purpose.

Outerline of civil foundation

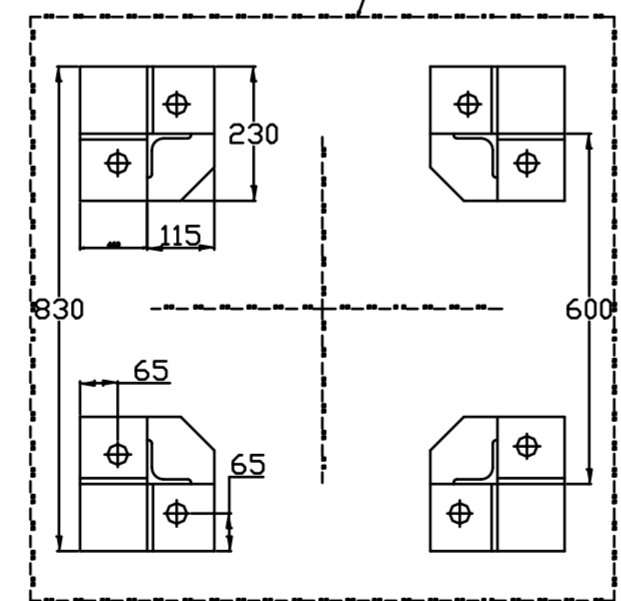

T.B
Detail of Item A

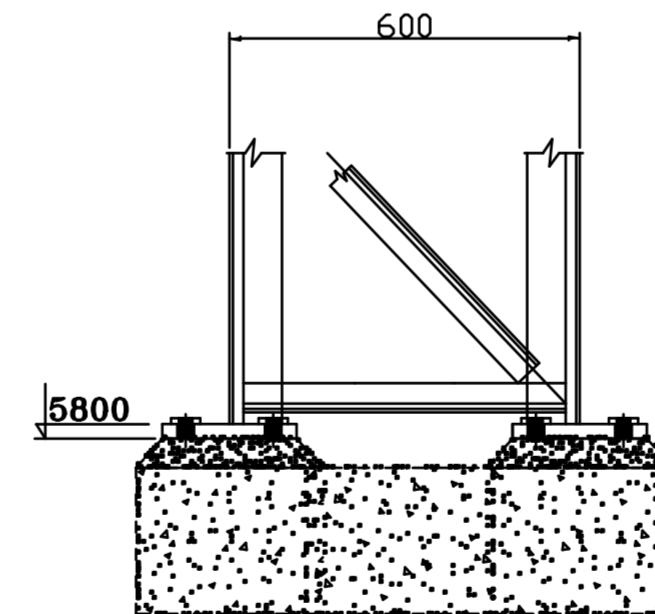

View B

Notes:
1.All dimensions are in 'mm'

INDEX	NL.	DESCRIPTION	REVISION SIGNATURE	DATE

	Location of columns		SK3200.01.472
	MATERIAL-		WEIGHT IN KG-
एच.ई.सी. BUREAU-CHIEF GROUP LEADER DESIGNER DRAWN BY REF.DRG.NO.	C.Prasad T.Prasad Raghupathi CAD	SCALE-NTS	H.M.B. HEC LTD.,RANCHI
			Nov'17 REV-0

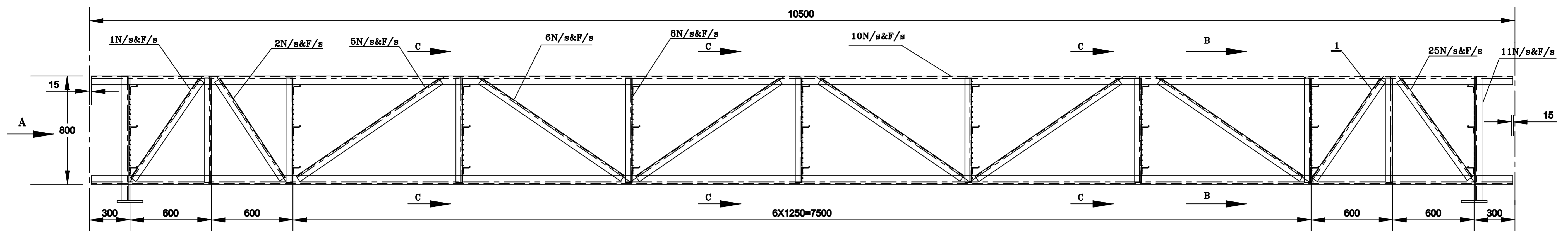

ELEVATION

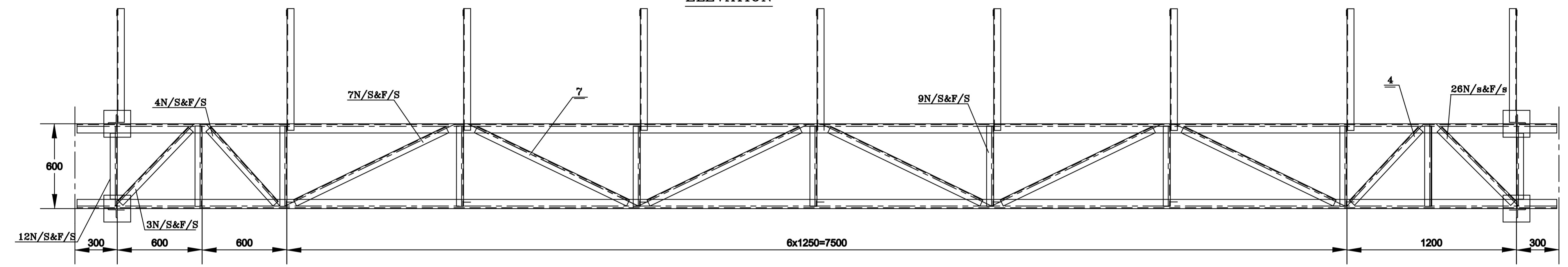

PLAN

Weld metal=11.73kg

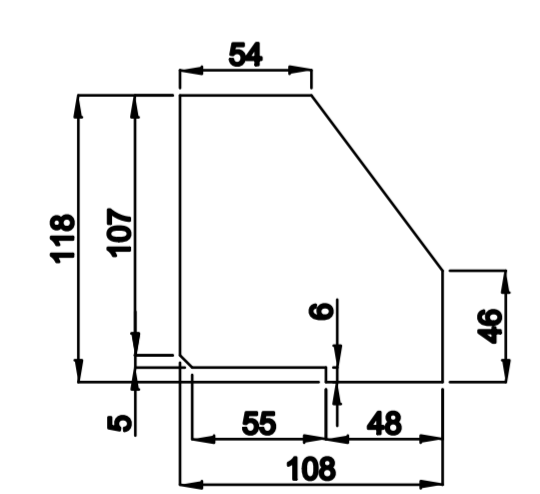
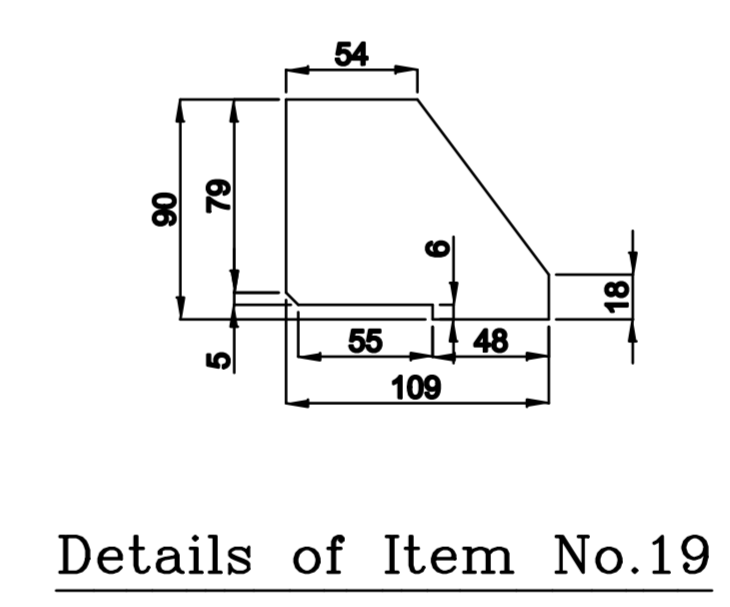
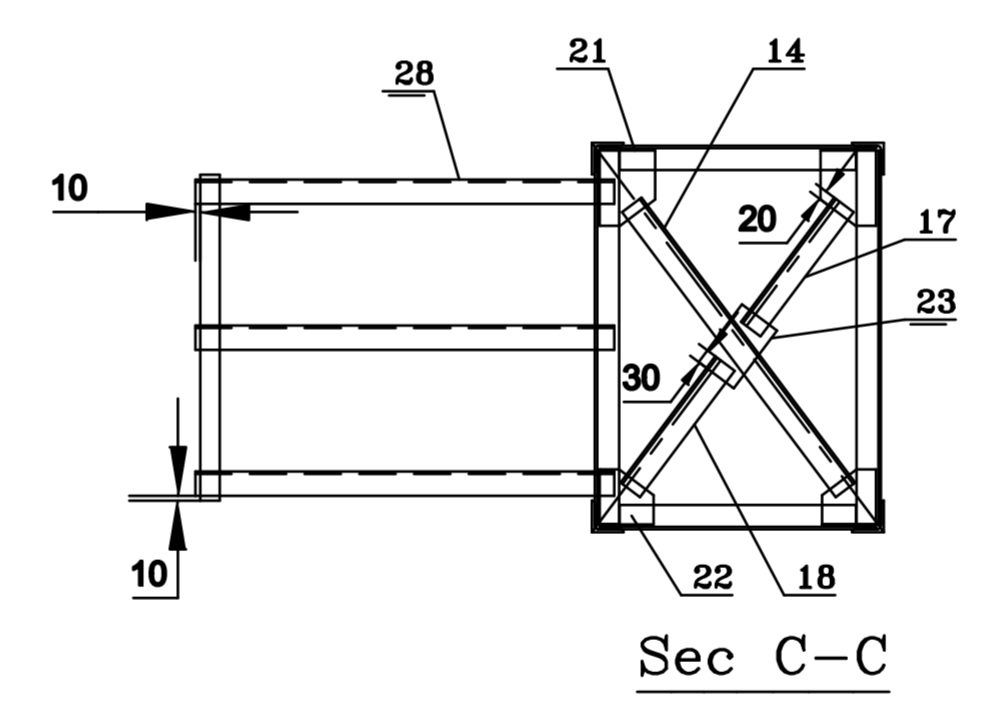
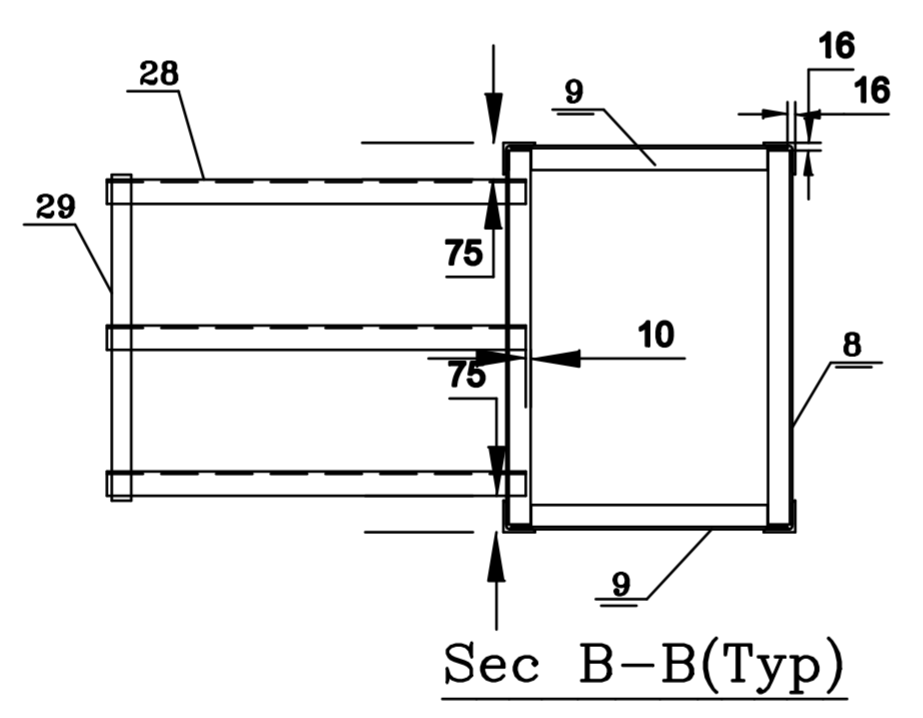
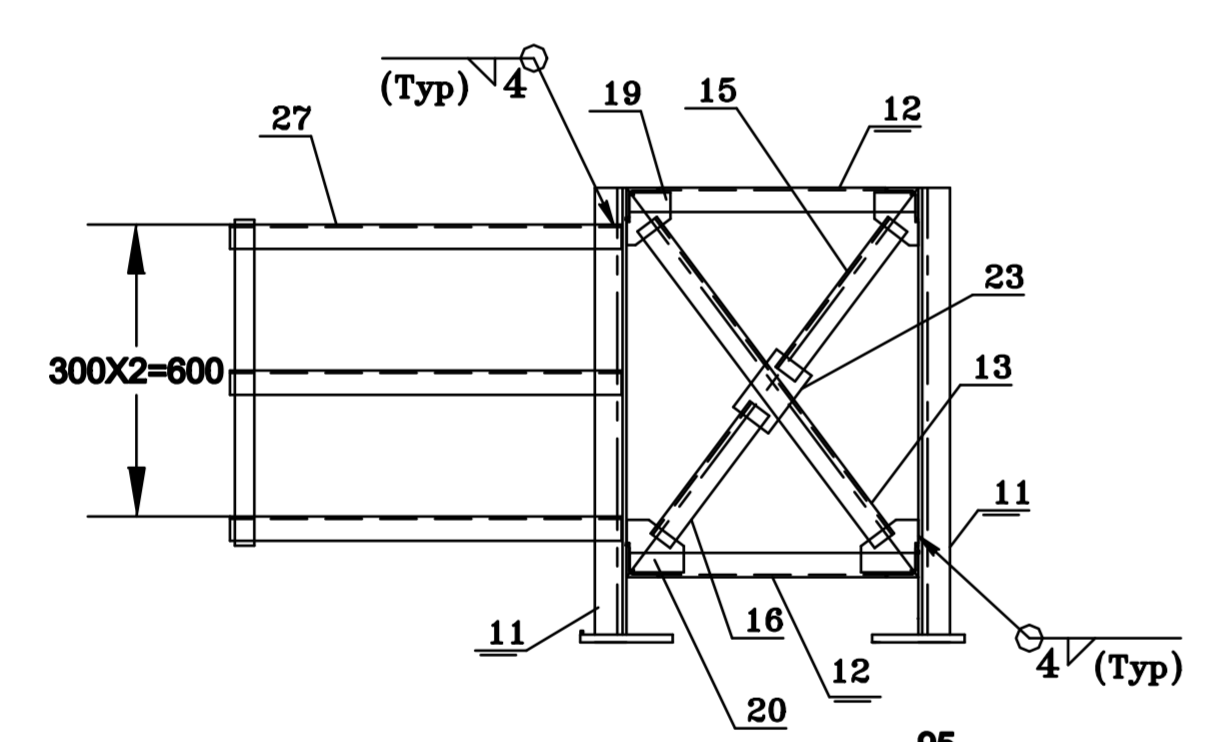

Details of Item No.20

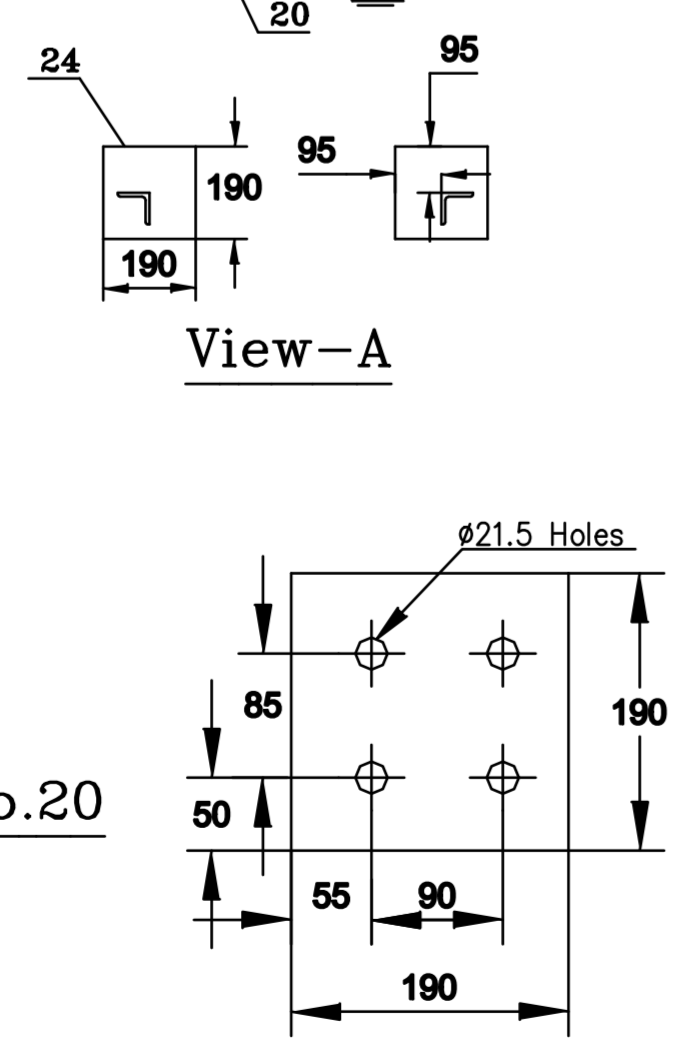

Details of Item No.24

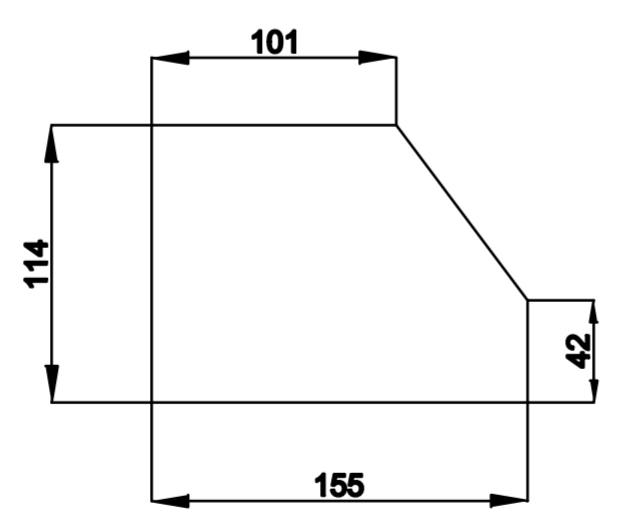

Details of Item No.21

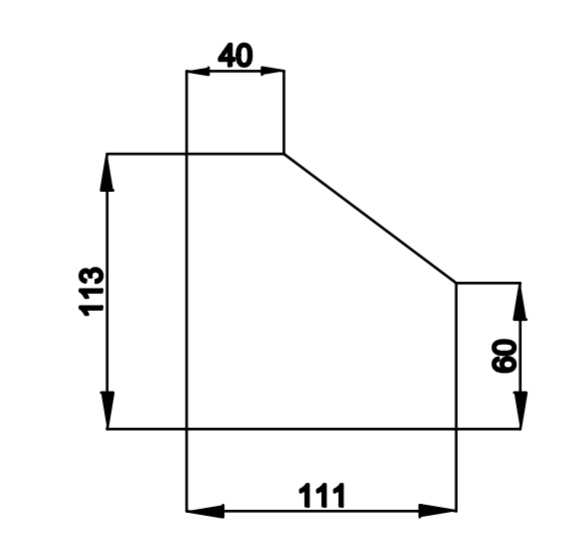

Details of Item No.22

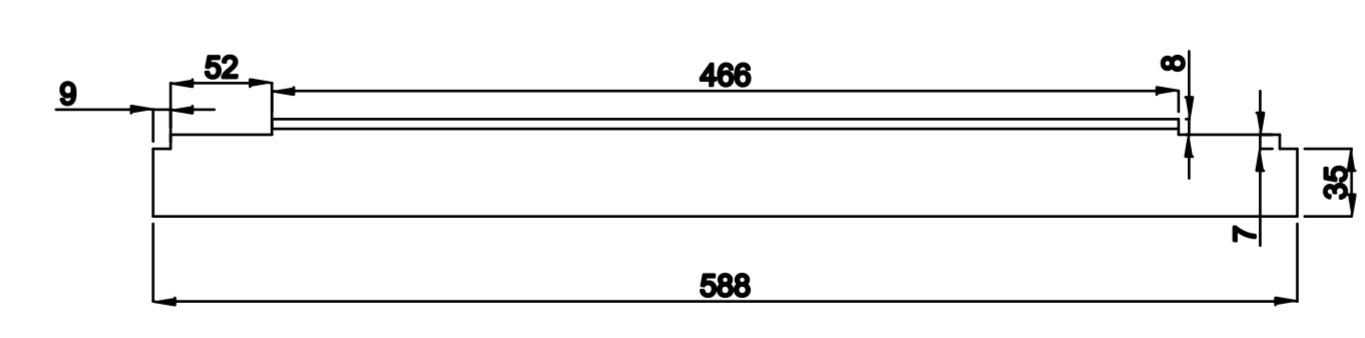

Details of Item No.12

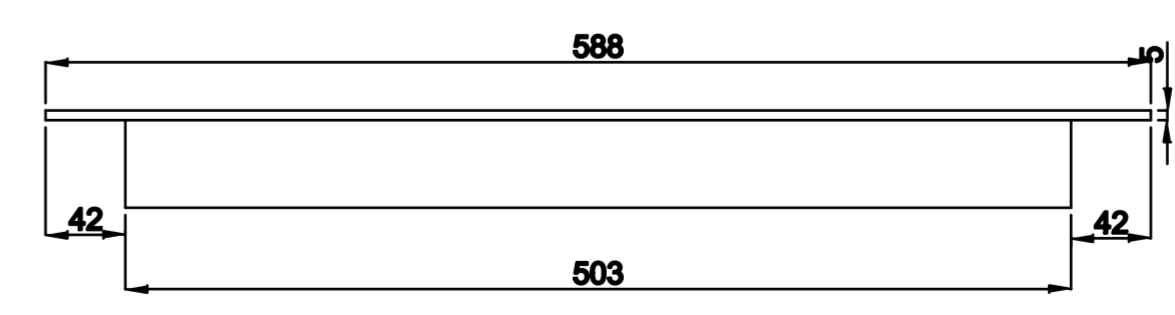

Details of Item No.9

Item No.	Drng. No.	Description	Material	No Off	Per Piece	Total	Remarks
29		ISF 40X4,L=670	Fe 410WA IS:2062-99	9	0.85	7.65	NO DRG.
28		ISA 50X50X5,L=860	Fe 410WA IS:2062-99	21	3.27	68.67	NO DRG.
27		ISA 50X50X5,L=805	Fe 410WA IS:2062-99	6	3.06	18.36	NO DRG.
26		ISA 50X50X5,L=735	Fe 410WA IS:2062-99	2	2.85	5.70	NO DRG.
25		ISA 50X50X5,L=890	Fe 410WA IS:2062-99	2	3.38	6.76	NO DRG.
24		ISPL 190X190X16	Fe 410WB IS:2062-99	4	4.54	18.16	
23		ISPL 148X90X6	Fe 410WB IS:2062-99	5	0.63	3.15	NO DRG.
22		ISPL 113X111X6	Fe 410WB IS:2062-99	6	0.50	3.00	
21		ISPL 155X114X6	Fe 410WB IS:2062-99	6	0.74	4.44	
20		ISPL 118X108X6	Fe 410WB IS:2062-99	4	0.49	1.96	
19		ISPL 109X90X6	Fe 410WB IS:2062-99	4	0.35	1.40	
18		ISA 50X50X5,L=325	Fe 410WA IS:2062-99	3	1.22	3.72	NO DRG.
17		ISA 50X50X5,L=319	Fe 410WA IS:2062-99	3	1.24	3.64	NO DRG.
16		ISA 50X50X5,L=340	Fe 410WA IS:2062-99	2	1.29	2.58	NO DRG.
15		ISA 50X50X5,L=385	Fe 410WA IS:2062-99	2	1.46	2.92	NO DRG.
14		ISA 50X50X5,L=732	Fe 410WA IS:2062-99	3	2.78	8.34	NO DRG.
13		ISA 50X50X5,L=813	Fe 410WA IS:2062-99	2	3.09	6.18	NO DRG.
12		ISA 50X50X5,L=588	Fe 410WA IS:2062-99	4	2.24	8.96	
11		ISA 65x65x8,L=918	Fe 410WA IS:2062-99	4	7.07	28.28	NO DRG.
10		ISA 65x65x6,L=10470	Fe 410WA IS:2062-99	4	60.73	243.0	NO DRG.
9		ISA 50X50X5,L=568	Fe 410WB IS:2062-99	18	2.16	38.90	
8		ISA 50X50X5,L=768	Fe 410WA IS:2062-99	18	2.92	52.56	NO DRG.
7		ISA 50X50X5,L=1195	Fe 410WA IS:2062-99	12	4.54	54.48	NO DRG.
6		ISA 50x50x5,L=1267	Fe 410WA IS:2062-99	6	4.82	28.92	NO DRG.
5		ISA 50x50x5,L=1275	Fe 410WA IS:2062-99	6	4.85	29.1	NO DRG.
4		ISA 50x50x5,L=710	Fe 410WA IS:2062-99	2	2.70	5.4	NO DRG.
3		ISA 50x50x5,L=719	Fe 410WA IS:2062-99	4	2.73	11.92	NO DRG.
2		ISA 50x50x5,L=873	Fe 410WA IS:2062-99	2	3.32	6.64	NO DRG.
1		ISA 50x50x5,L=886	Fe 410WA IS:2062-99	4	3.37	13.48	NO DRG.

Notes

- 1.All dimensions are in mm unless otherwise noted.
- 2.Suitable electrode as per IS:814-91 shall be used.
- 3.All welds are of 4mm unless otherwise noted.
- 4.All dimensions are in mm.

INDEX	NO.	DESCRIPTION	REVISION	SIGNATURE	DATE

1520.26.032
 GIRDER;GR-1; L=10500
 MATERIAL- Assembly
 SCALE: 1:15 WEIGHT IN KG- 700
 BUREAU-CHIEF C.Prasad
 GROUP LEADER T.Prasad
 DESIGNER Raghupathi
 DRAWN BY CAD
H.M.B.
 HEC LTD.,RANCHI
 Sep'17
 REV-0

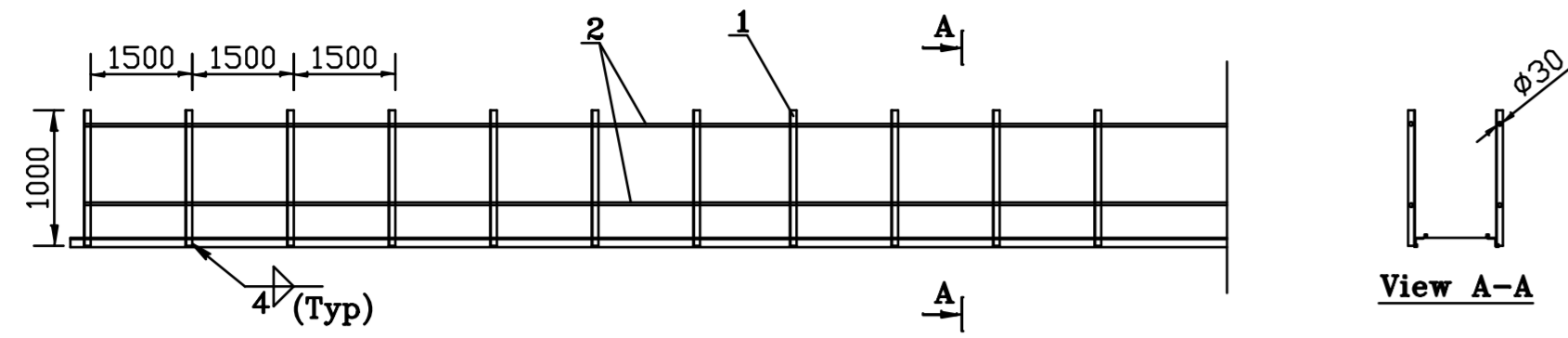

Elevation for Hand Railing (Typ.)

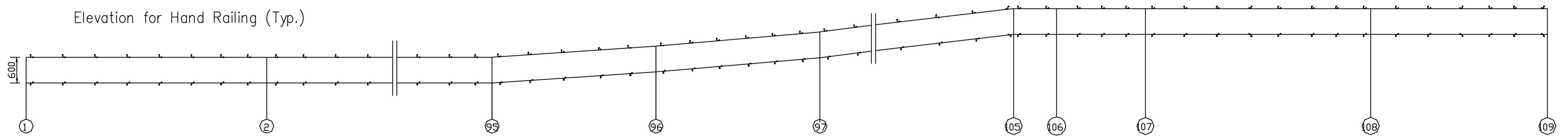

Plan for Hand railing

(NOT TO SCALE)

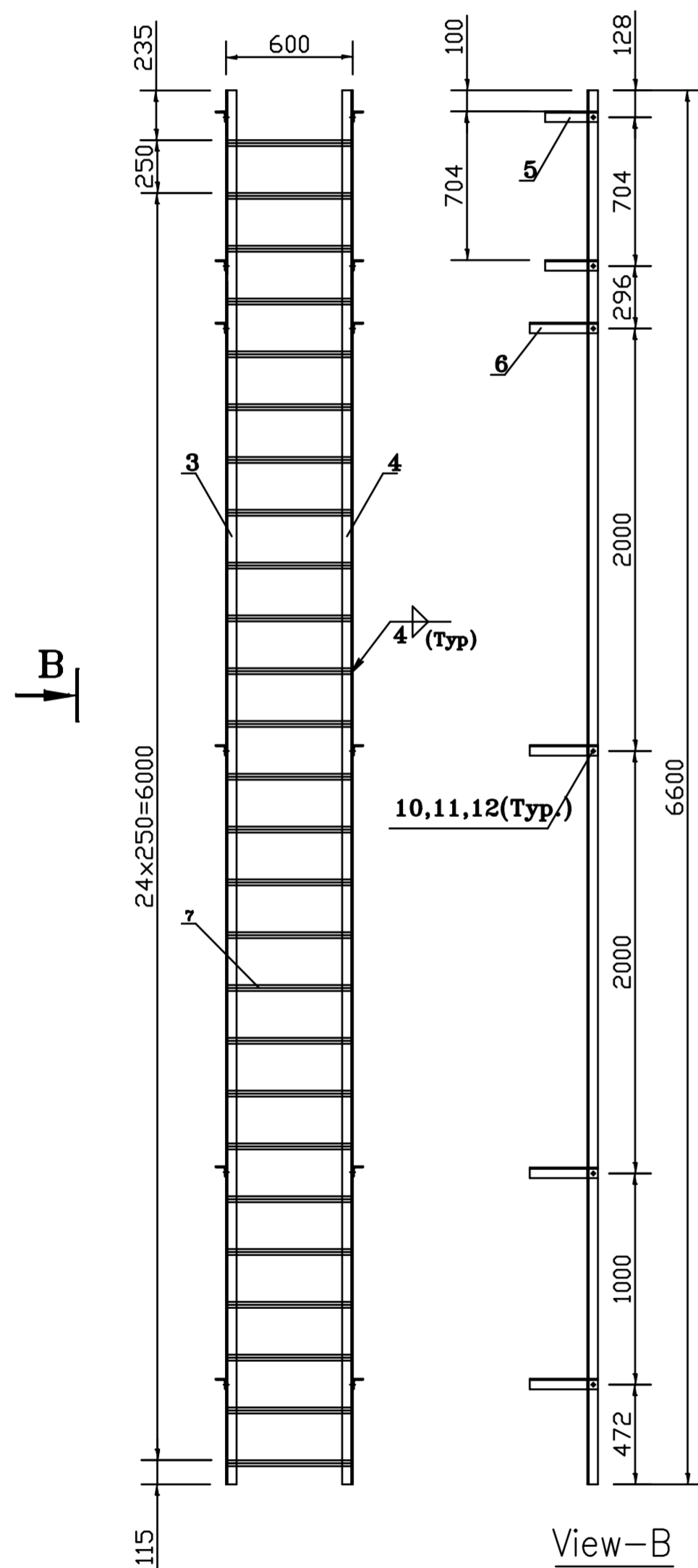

Ladder (Typ)

Ladder to be placed at 105(tentative) m interval

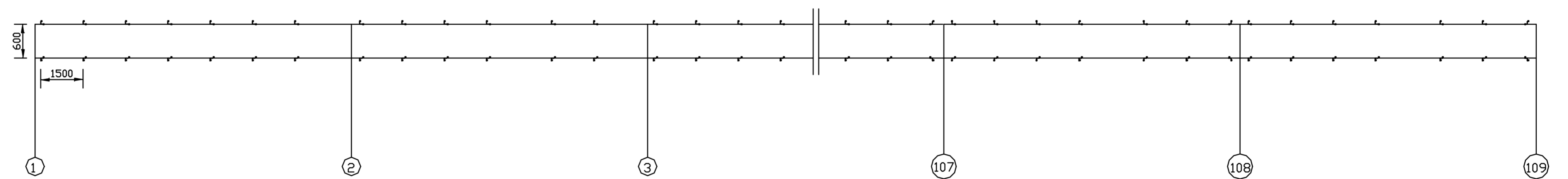

Plan for Hand railing

(NOT TO SCALE)

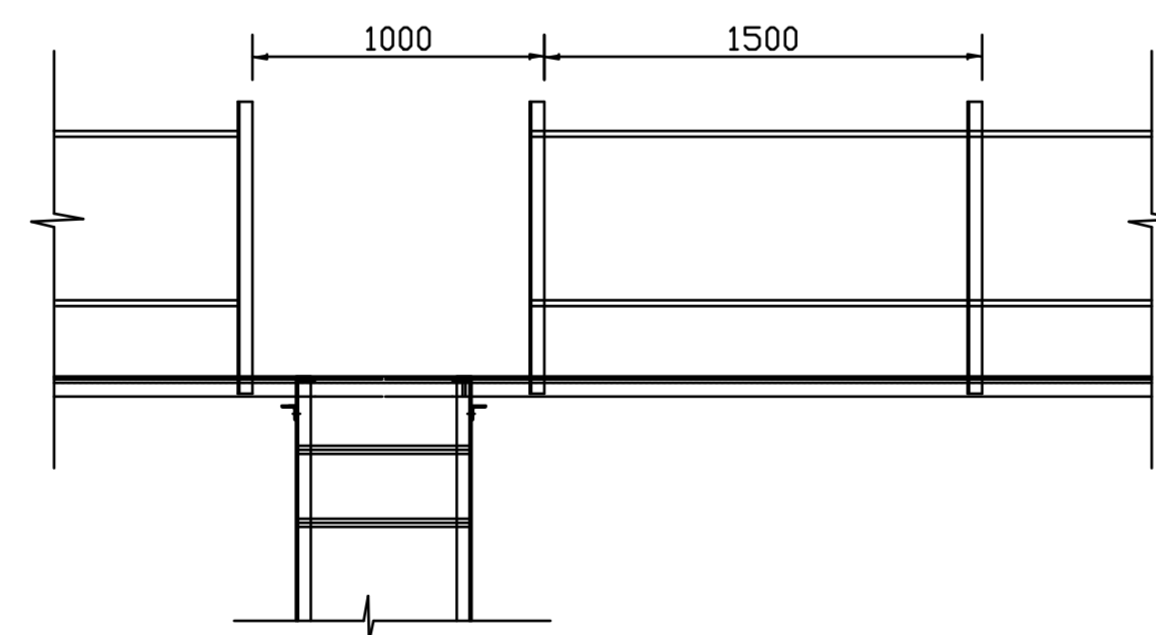

Hand railing at Ladder position

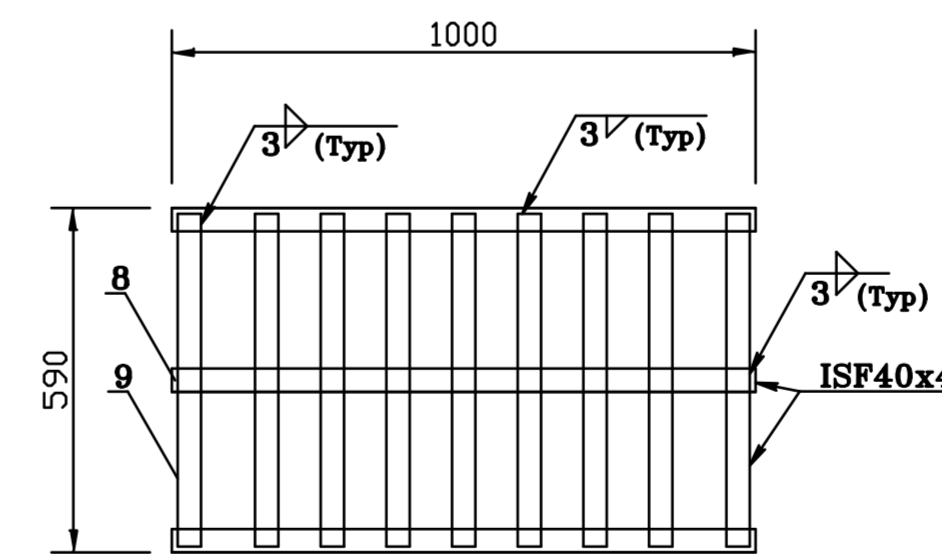

Grating Details (Typ)

12	Flate Ends Spring Washer 10	Spring Steel	12	For one ladder			
11	Hex. Nut M10	PC B IS:1367-91	12	For one ladder			
10	Hex. Head Screw M10x35	PC B.8 IS:1367-91	12	For one ladder			
9	ISF 40X4,L=570	Fe 410WA IS:2062-99					
8	ISF 40X4,L=1000	Fe 410WA IS:2062-99					
7	Tube 20(M) IS:1239;L=590	Fe 410WA IS:2062-99					
6	ISA 50x50x5,L=323	Fe 410WA IS:2062-99					
5	ISA 50x50x5,L=250	Fe 410WA IS:2062-99					
4	ISA 50x50x5,L=6600	Fe 410WA IS:2062-99					
3	ISA 50x50x5,L=6600	Fe 410WA IS:2062-99					
2	Tube 20(M) IS:1239	Fe 410WA IS:2062-99					
1	ISA 50x50x5,L=1000	Fe 410WA IS:2062-99					
Item No.	Drng. No.	Description	Material	No Dff	Per Piece	Total	Remarks

This drawing is indicative only and has been prepared for Quotation purpose.

Note: All dimensions are in 'mm'

INDEX	NO.	DESCRIPTION	REVISIONS	SIGNATURE	DATE

Misc Items(Platform Ladder,Grating,HR etc.)
 SK3200.01.471
 MATERIAL-
 WEIGHT IN KG-
 SCALE-NTS
 BUREAU-CHIEF C.Prasad
 GROUP LEADER T.Prasad
 DESIGNER Raghupathi
 DRAWN BY CAD
H.M.B.
 HEC LTD.,RANCHI
 Nov'17
 REV-0